

SYSTEM WIRING DIAGRAMS

Cooling Fan Circuit

1993 Volvo 940

cdr@wp.pl

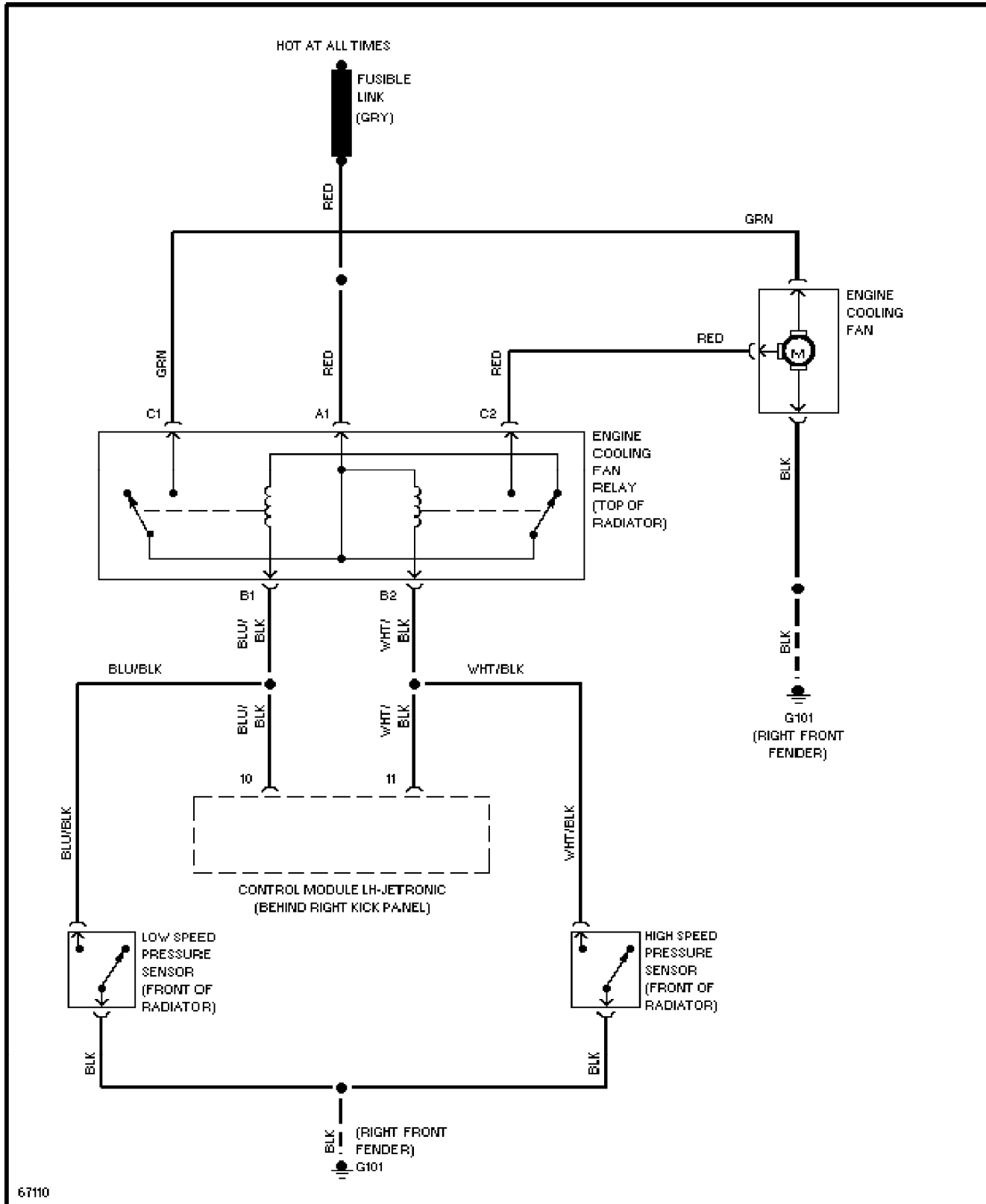

SYSTEM WIRING DIAGRAMS

Front Washer/Wiper Circuit

1993 Volvo 940

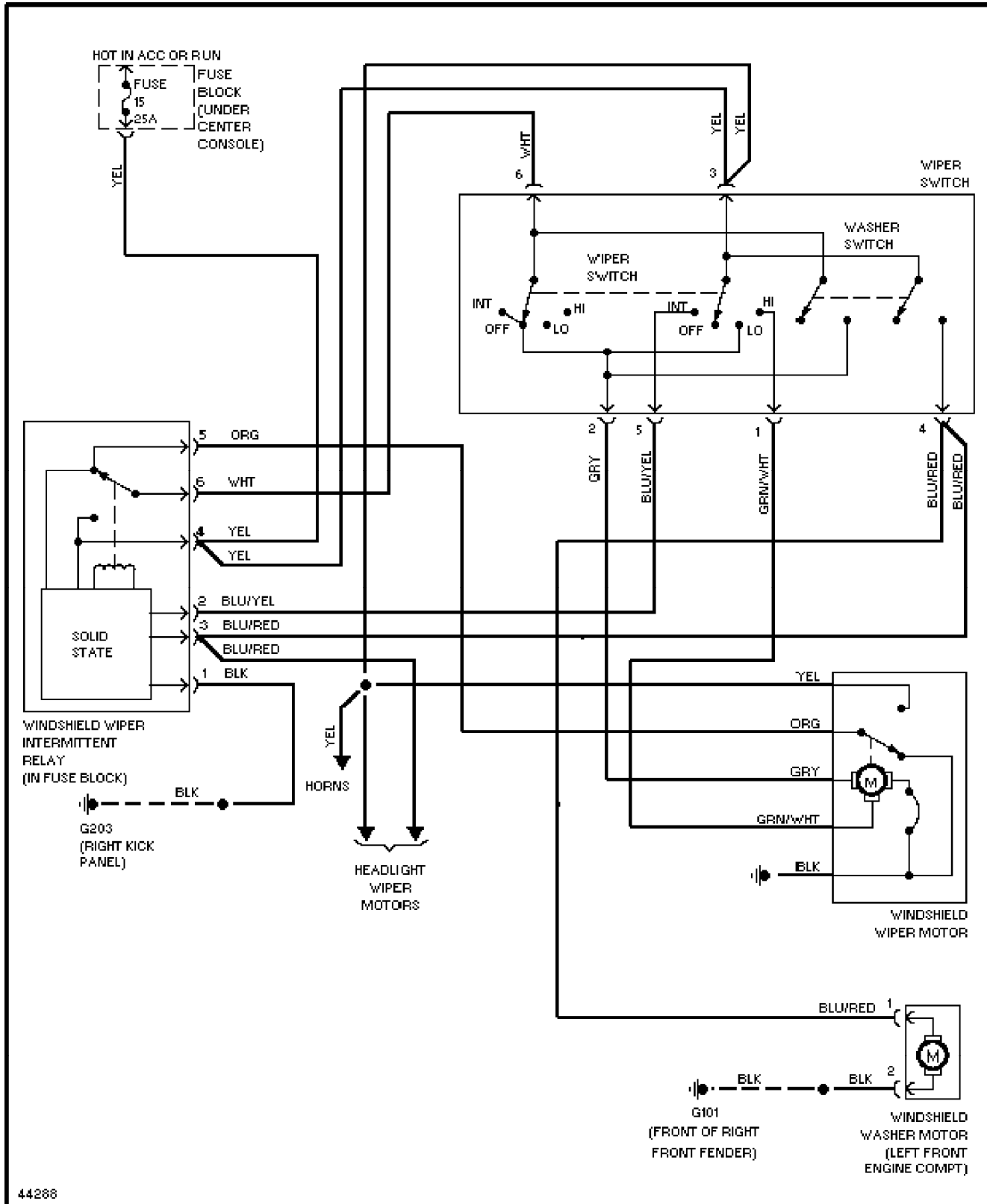

SYSTEM WIRING DIAGRAMS

Headlight Washer/Wiper Circuit

1993 Volvo 940

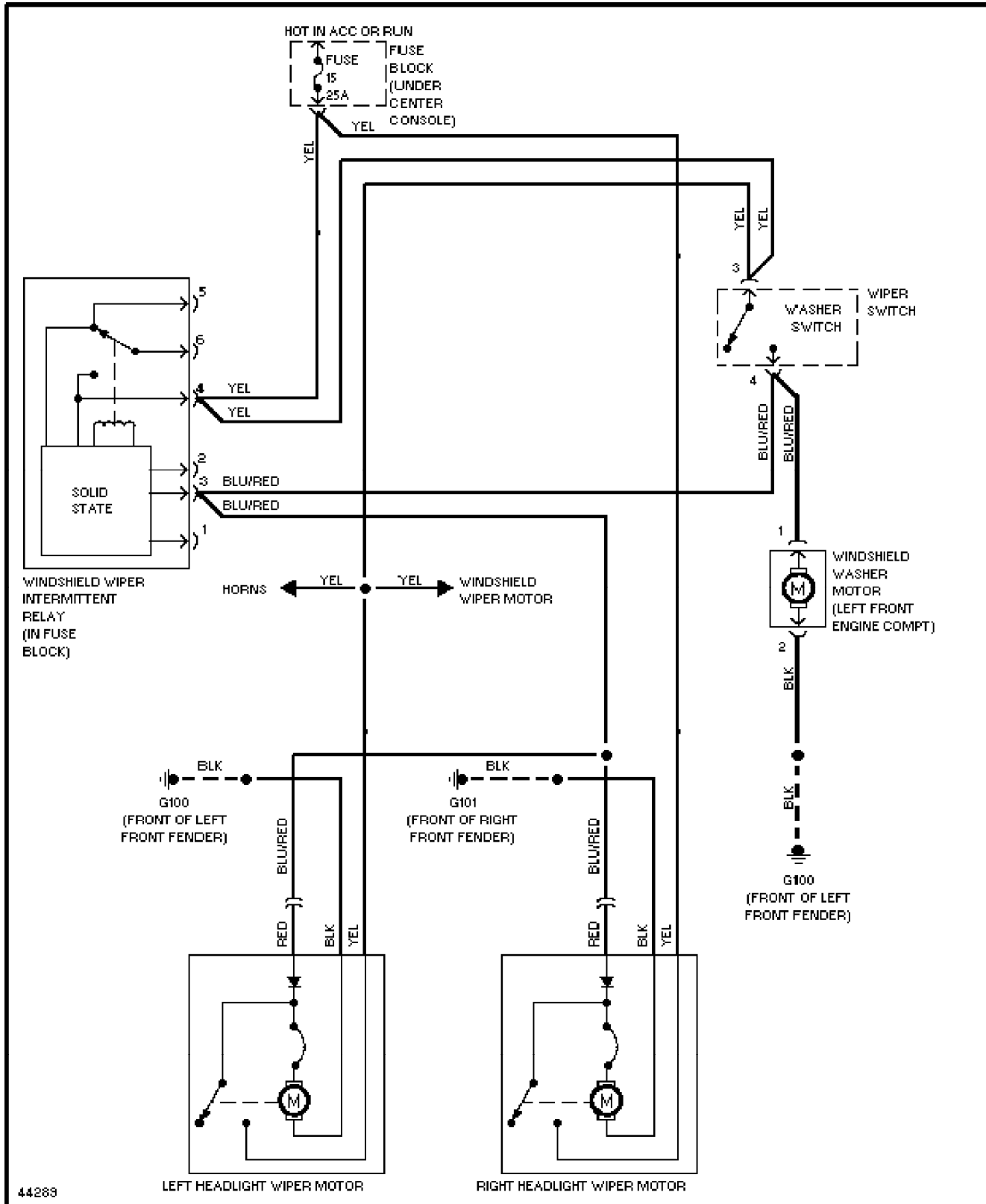

SYSTEM WIRING DIAGRAMS

Rear Washer/Wiper Circuit

1993 Volvo 940

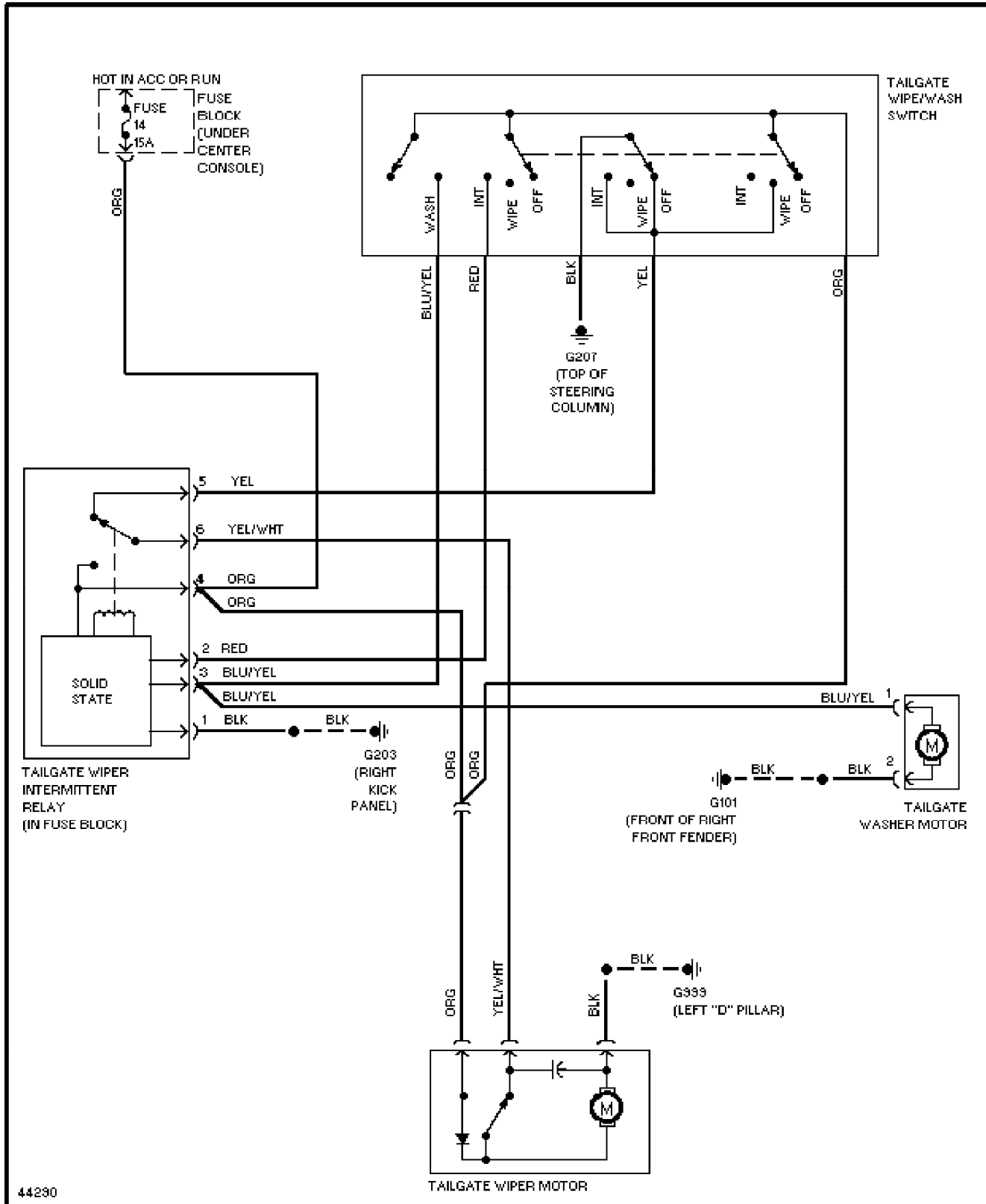

SYSTEM WIRING DIAGRAMS

Defogger Circuit

1993 Volvo 940

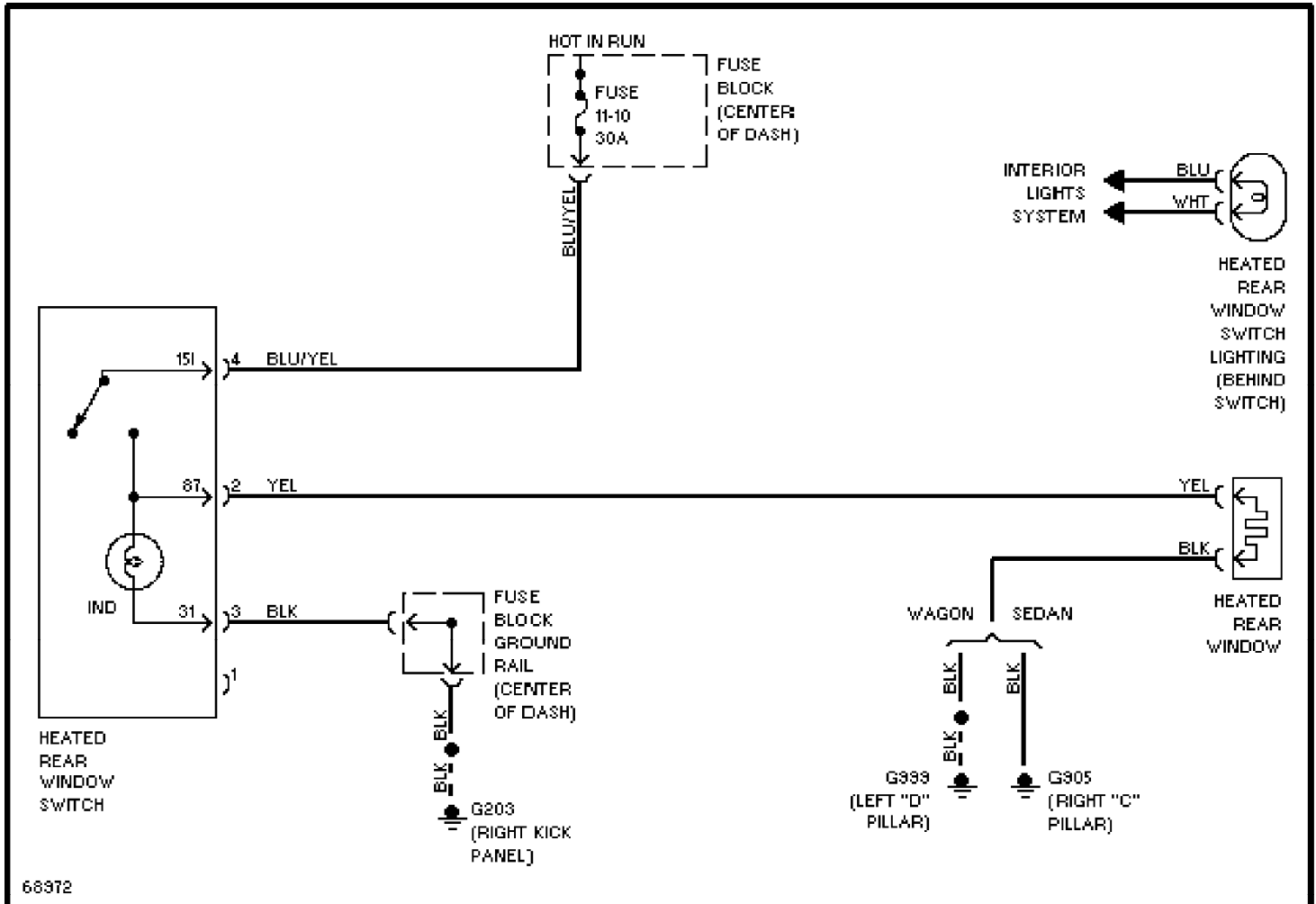

SYSTEM WIRING DIAGRAMS

Rear Defogger & Heated Mirrors Circuit

1993 Volvo 940

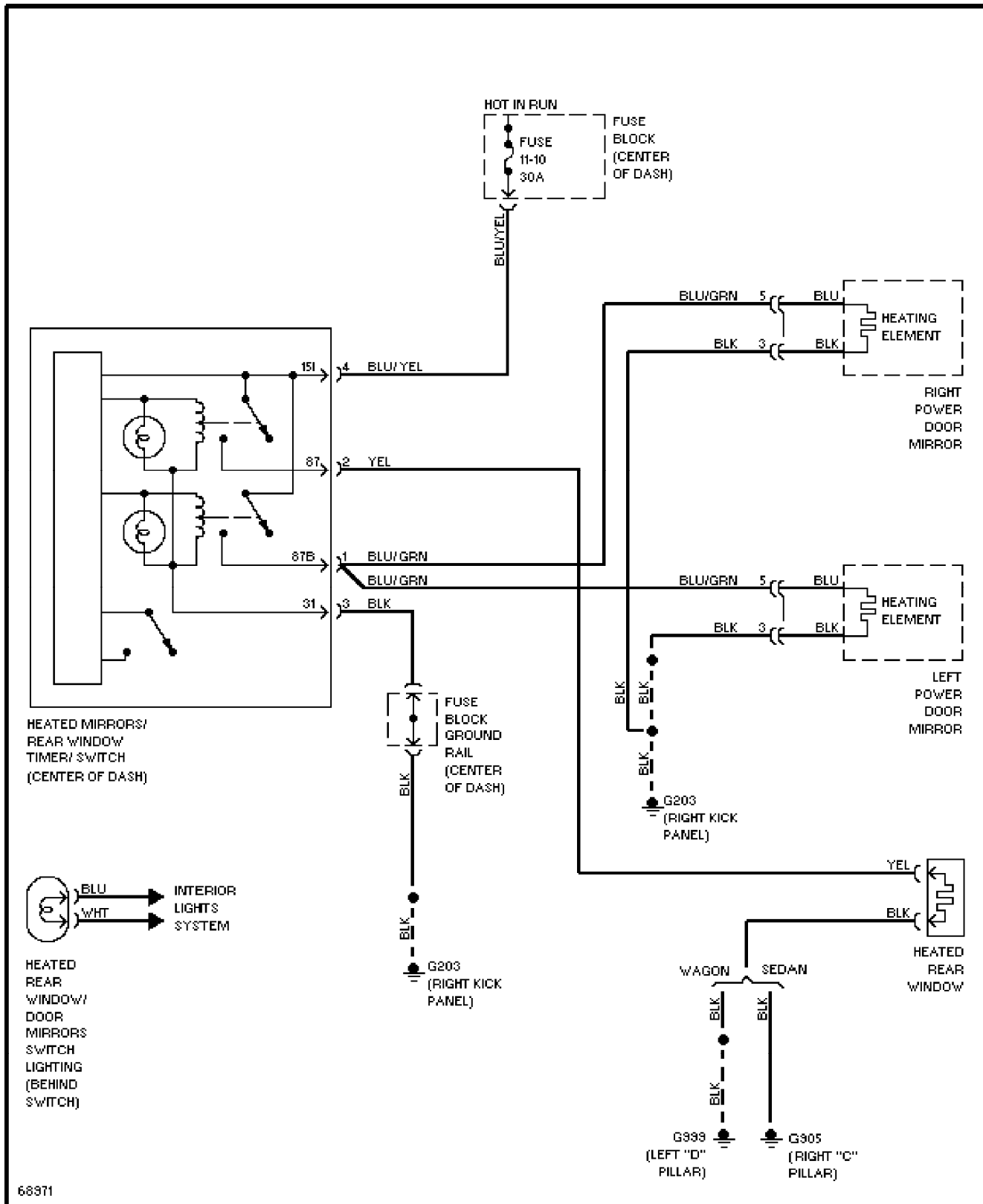

SYSTEM WIRING DIAGRAMS

Horn Circuit

1993 Volvo 940

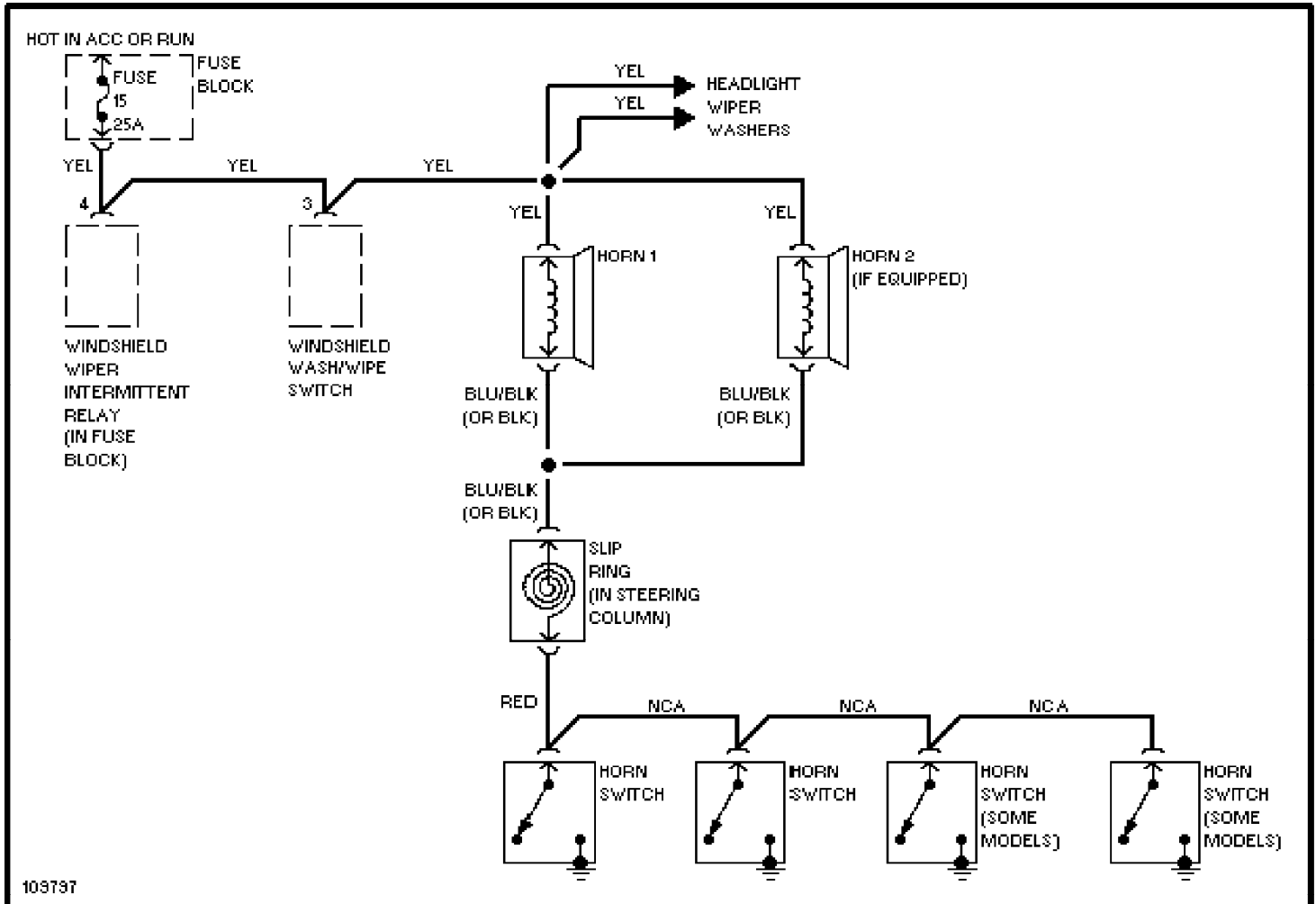

SYSTEM WIRING DIAGRAMS

Memory Seat Circuit

1993 Volvo 940

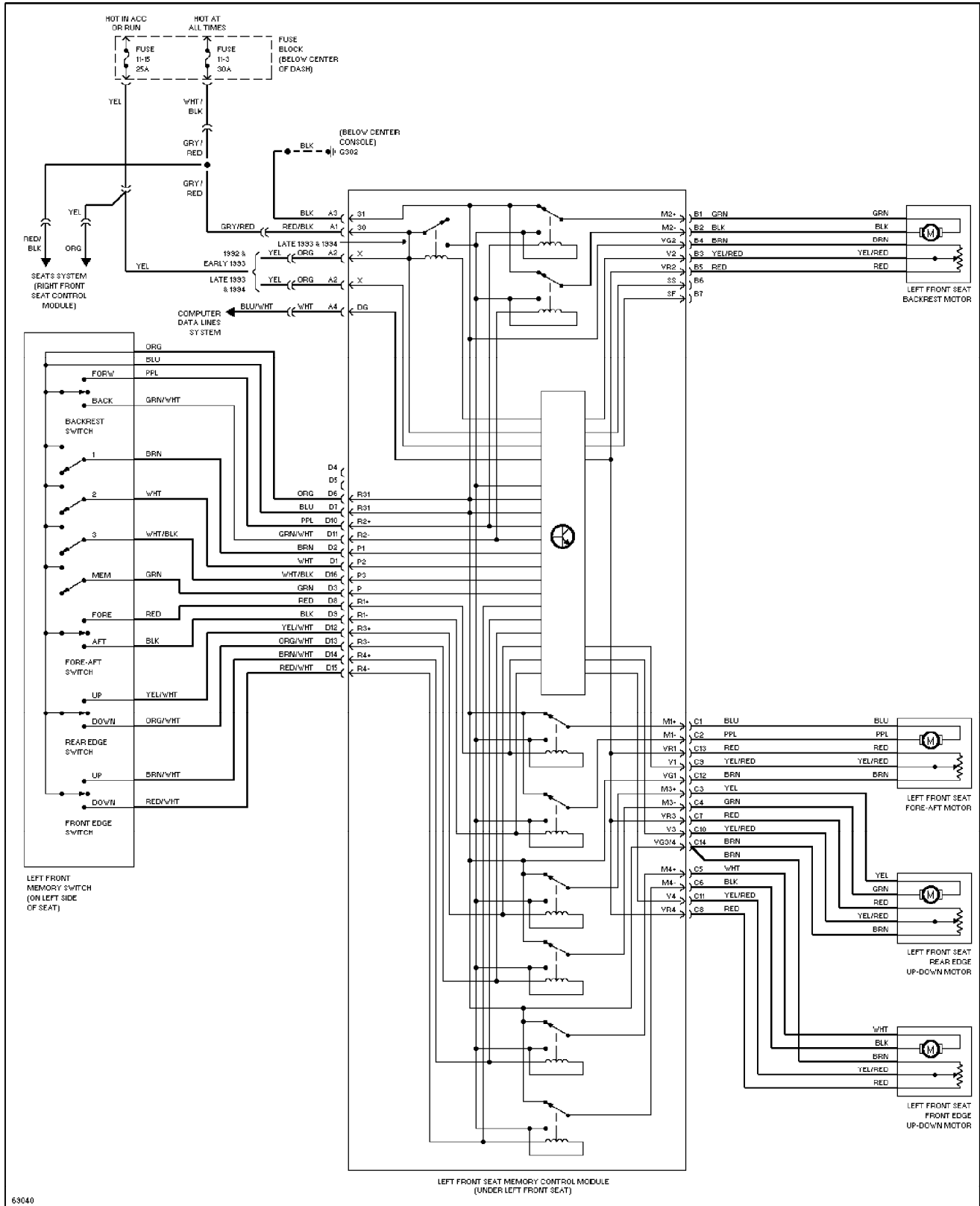

SYSTEM WIRING DIAGRAMS

Power Antenna Circuit

1993 Volvo 940

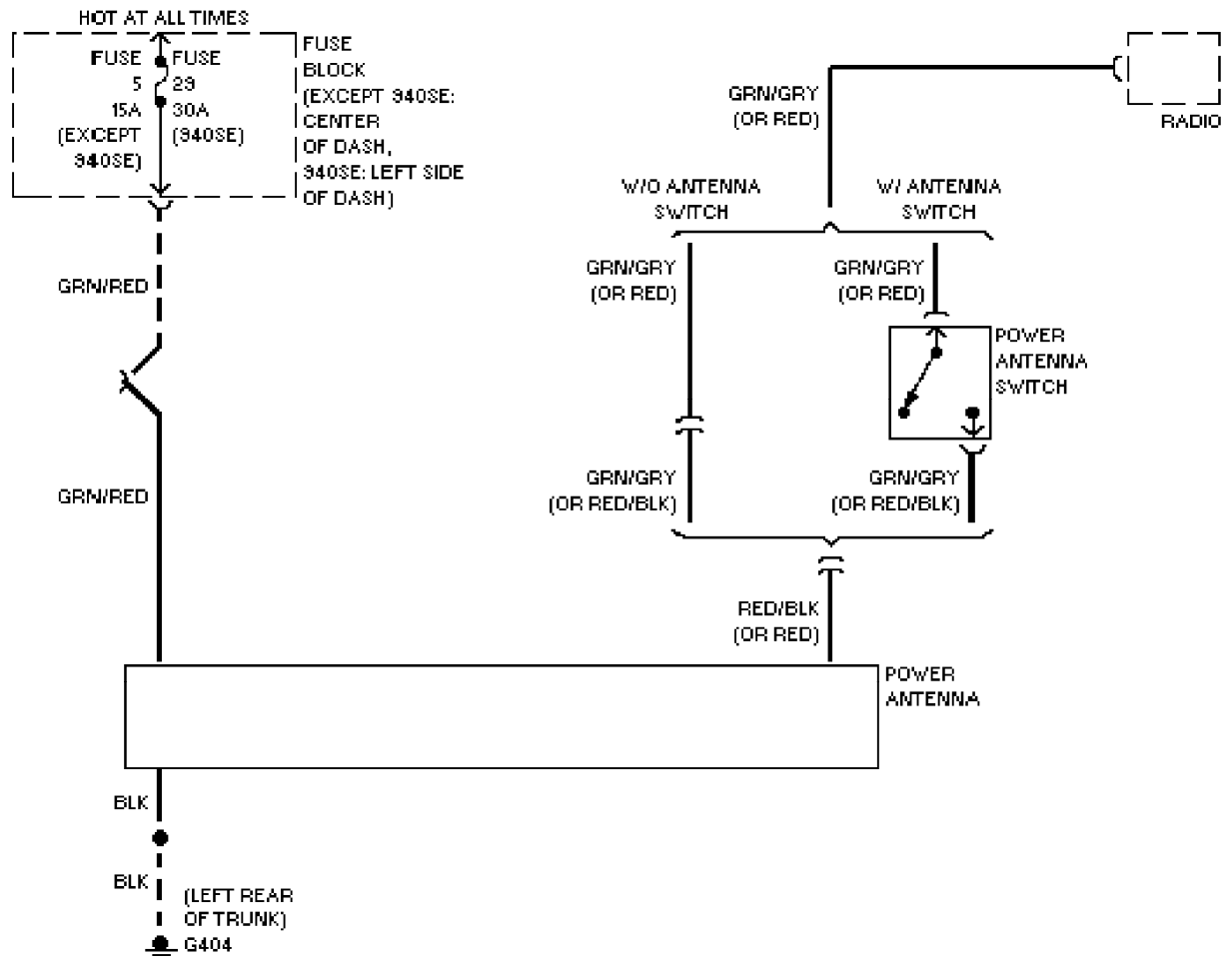

SYSTEM WIRING DIAGRAMS

Power Door Lock Circuit

1993 Volvo 940

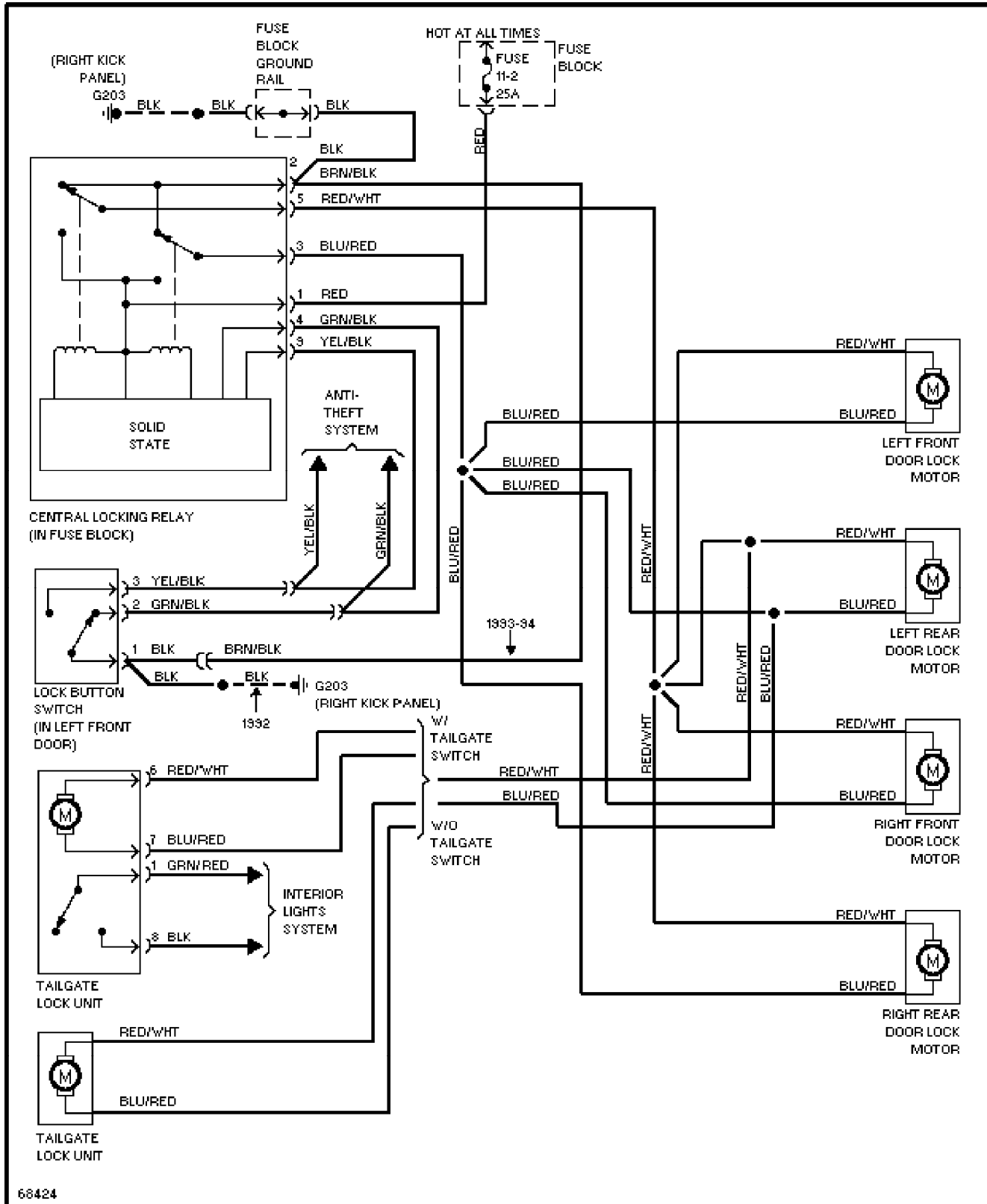

SYSTEM WIRING DIAGRAMS

Power Mirror Circuit

1993 Volvo 940

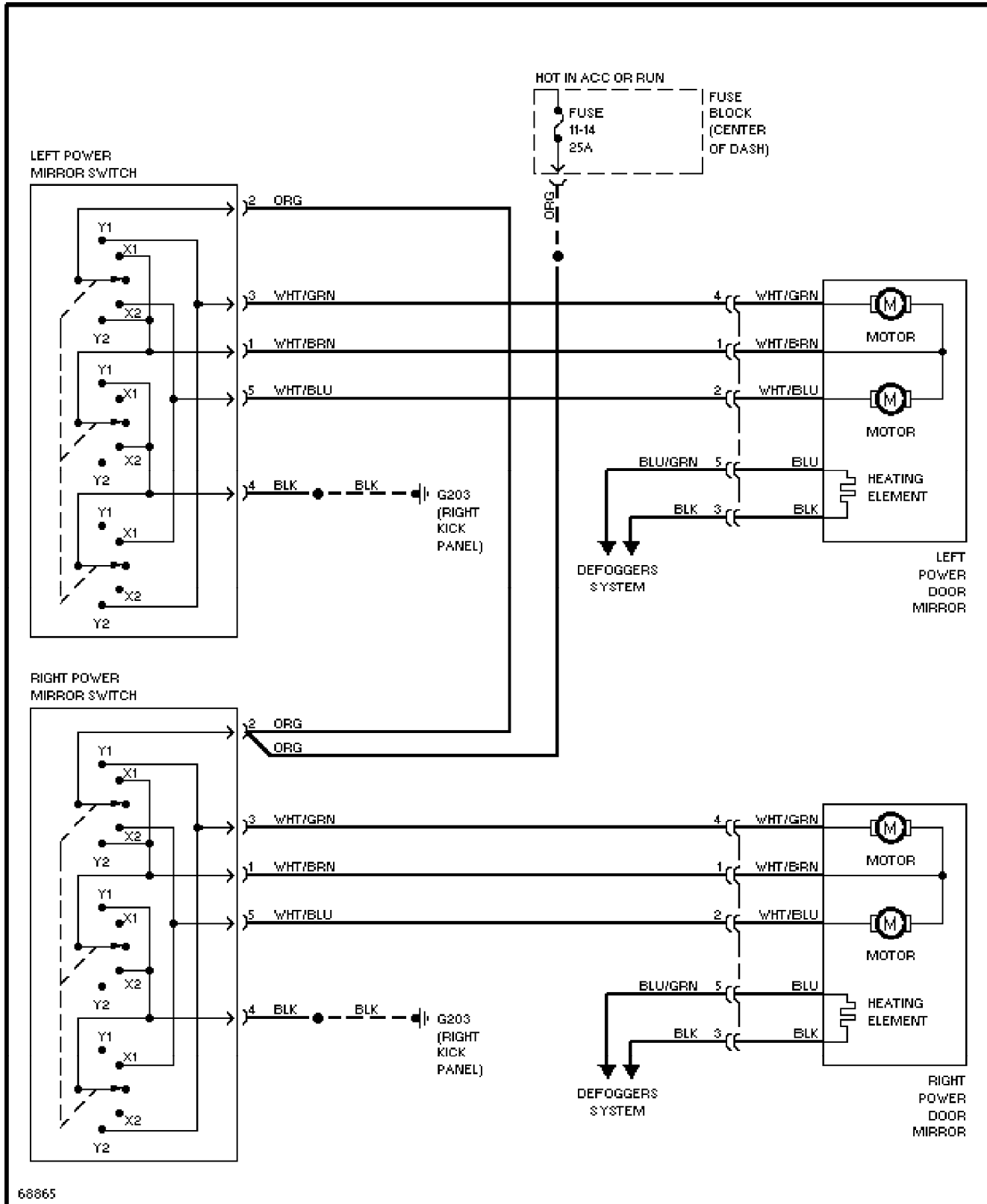

SYSTEM WIRING DIAGRAMS

Heated Seats Circuit, High Output

1993 Volvo 940

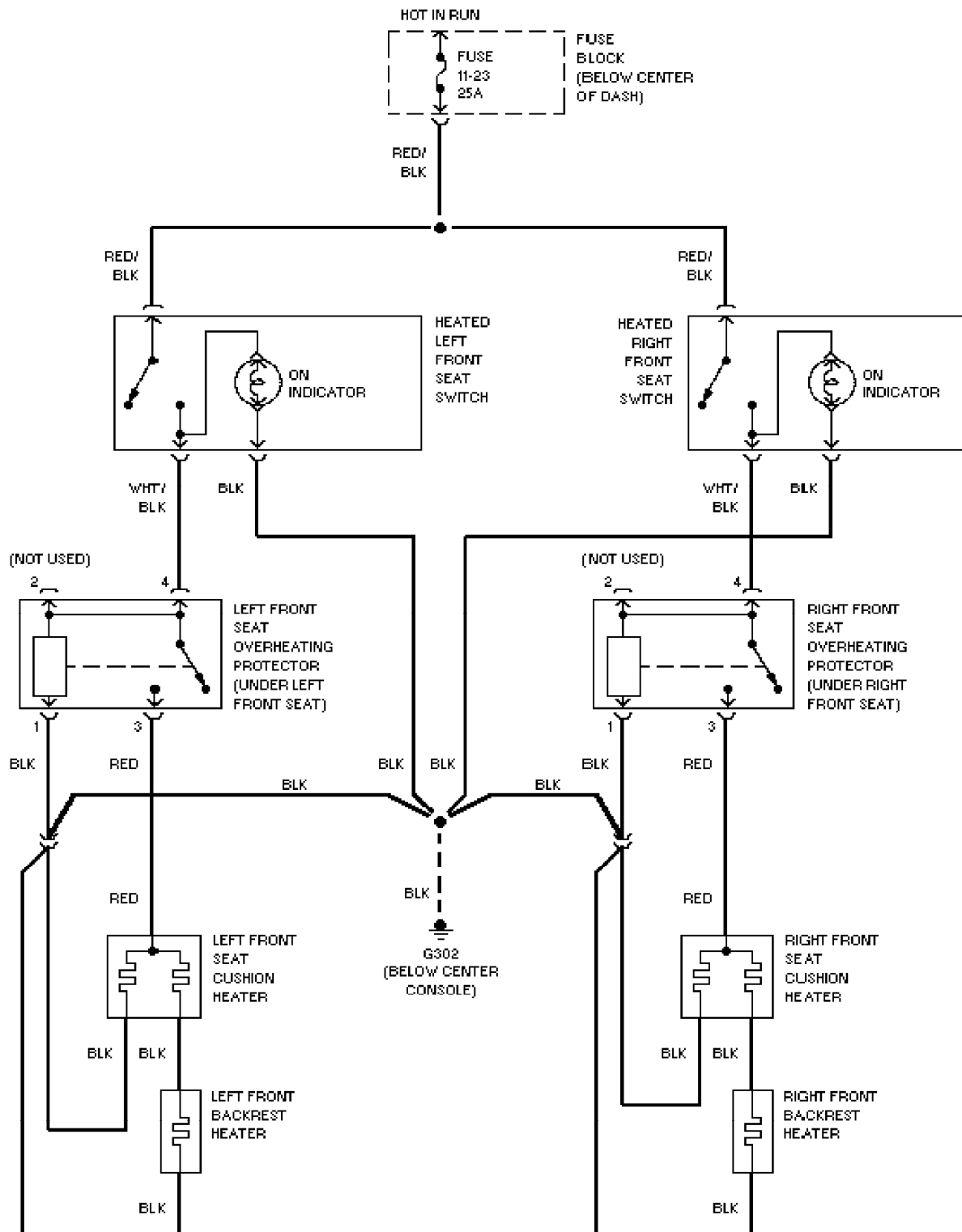

SYSTEM WIRING DIAGRAMS
Heated Seats Circuit, Normal Output
1993 Volvo 940

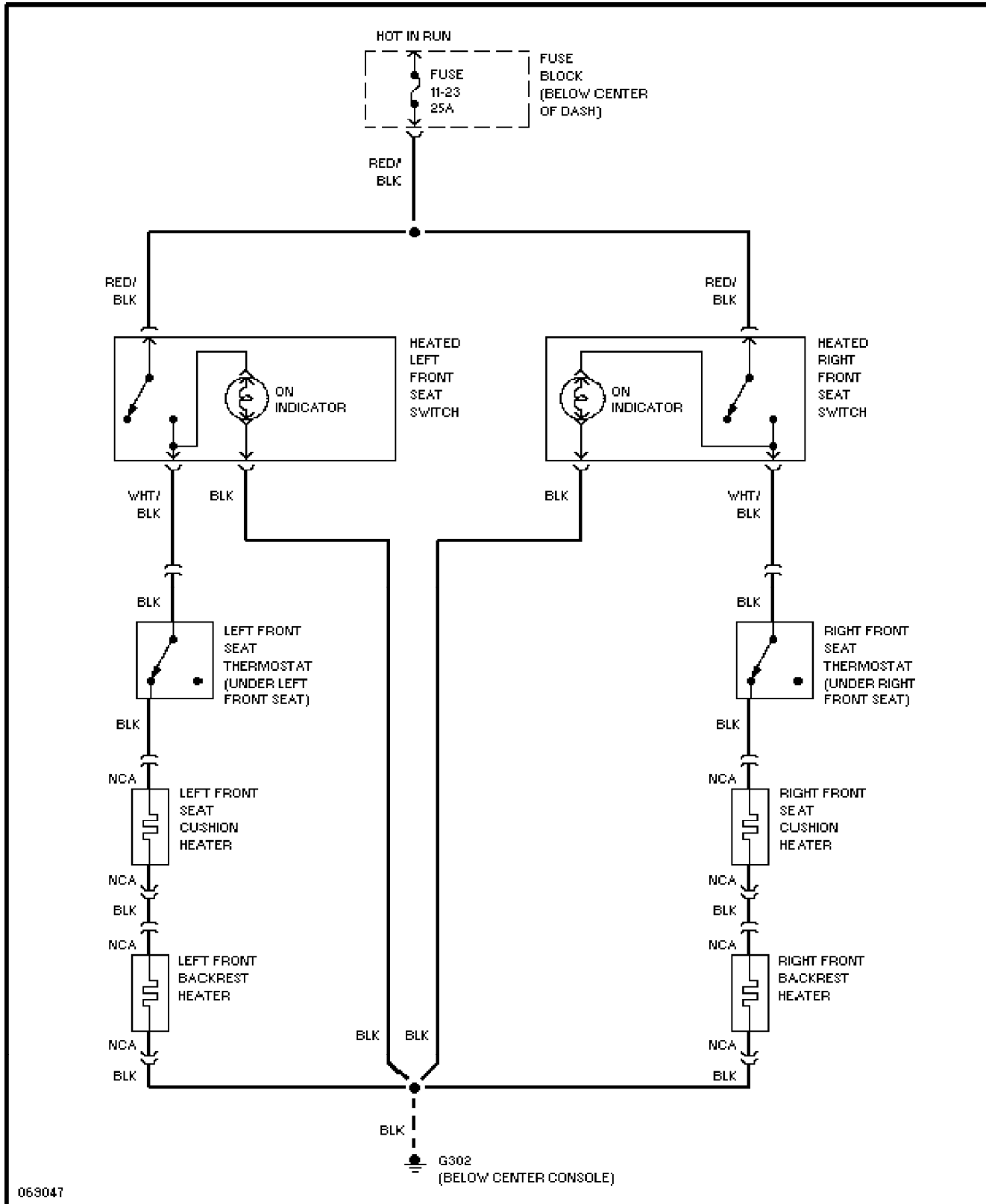

SYSTEM WIRING DIAGRAMS

Power Seats Circuit

1993 Volvo 940

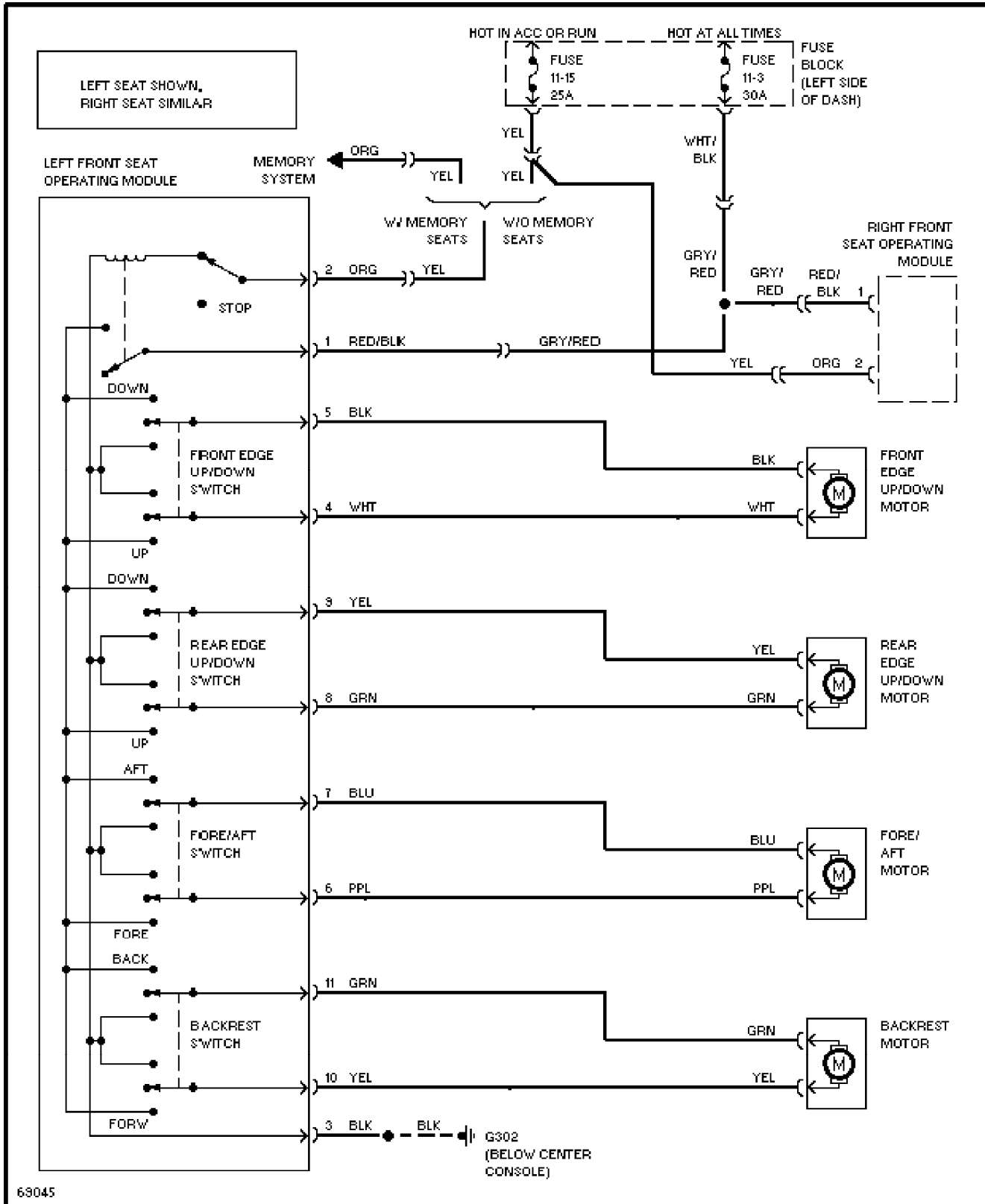

SYSTEM WIRING DIAGRAMS

Power Window Circuit

1993 Volvo 940

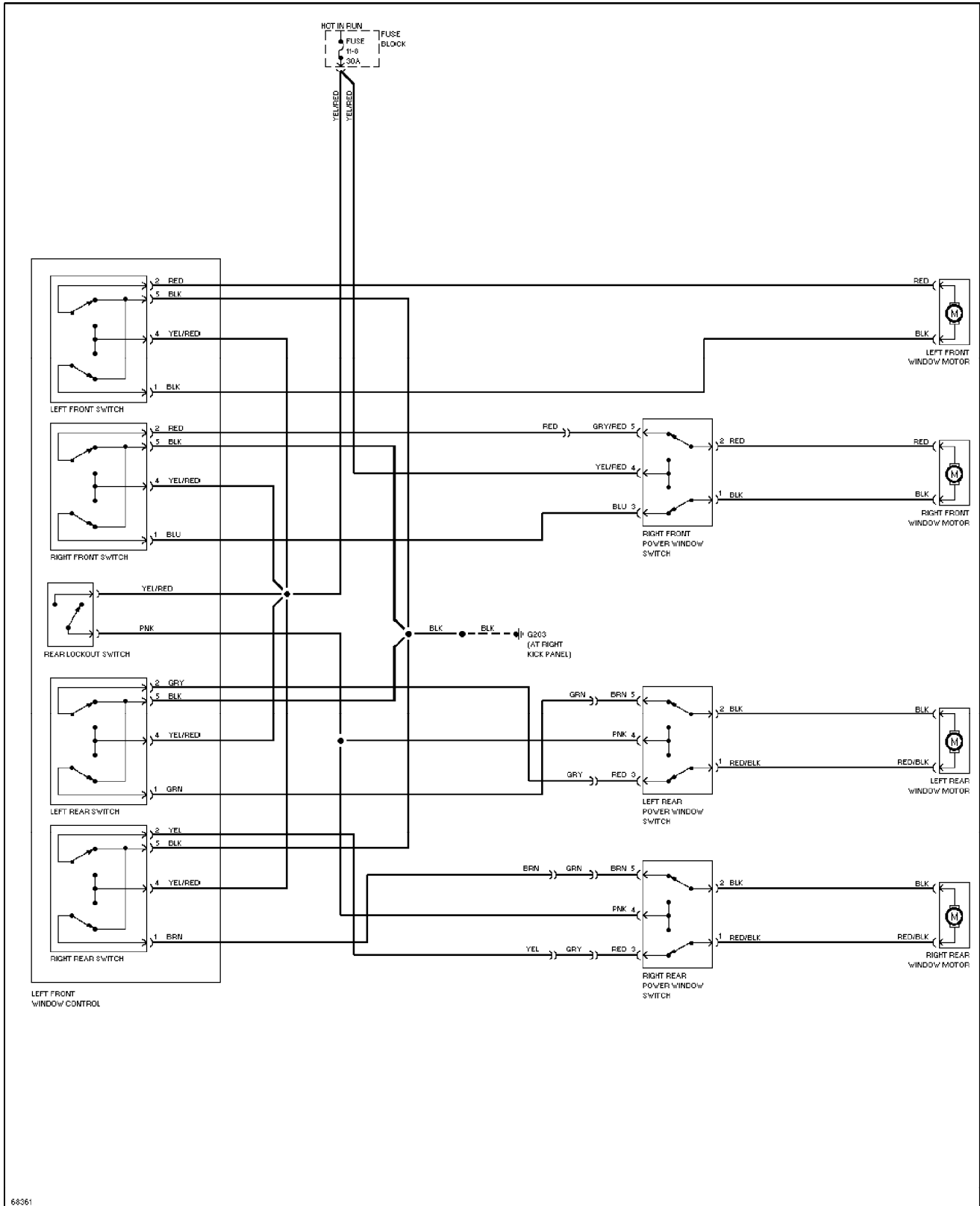

SYSTEM WIRING DIAGRAMS

Radio Circuits

1993 Volvo 940

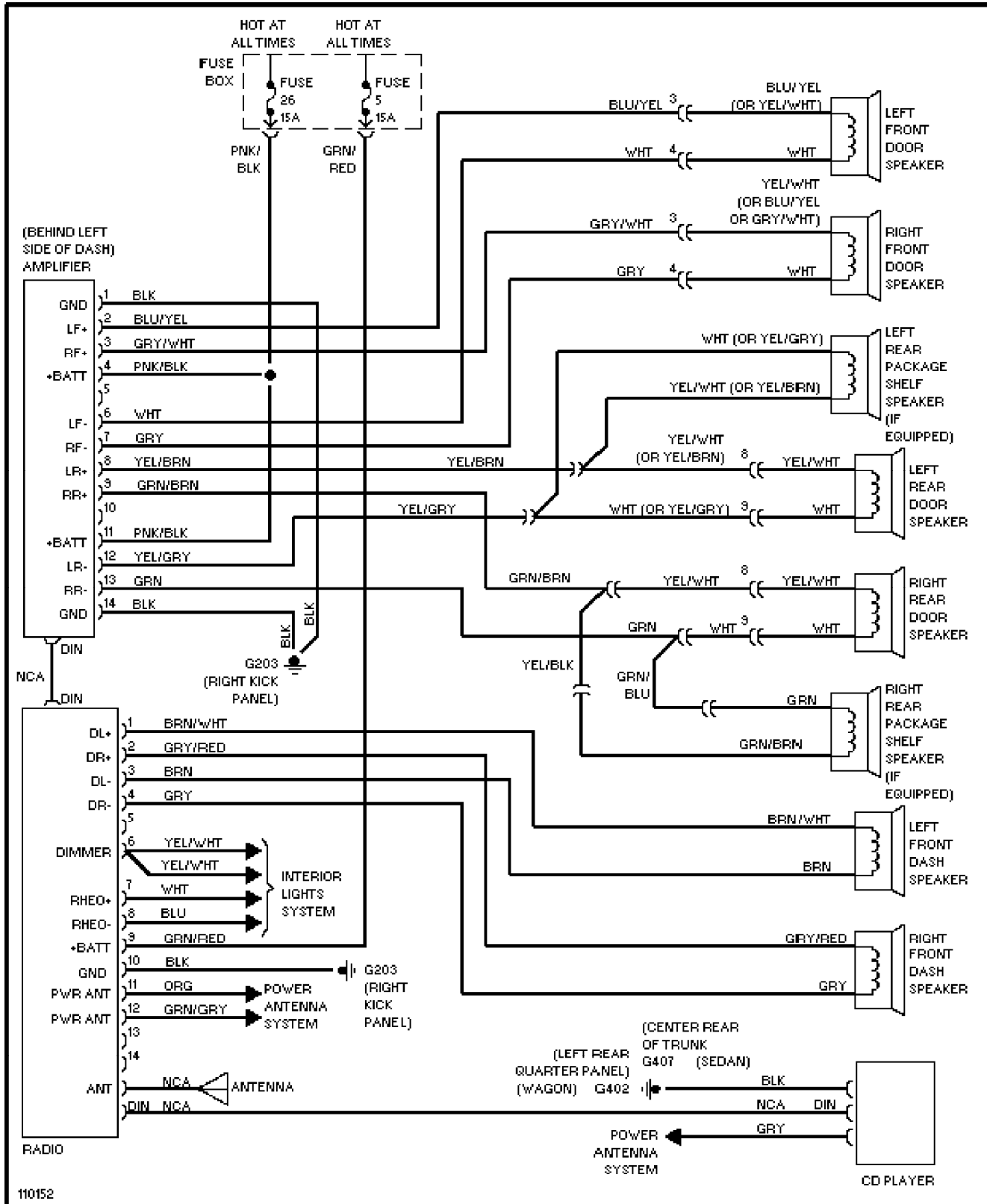

SYSTEM WIRING DIAGRAMS

Charging Circuit

1993 Volvo 940

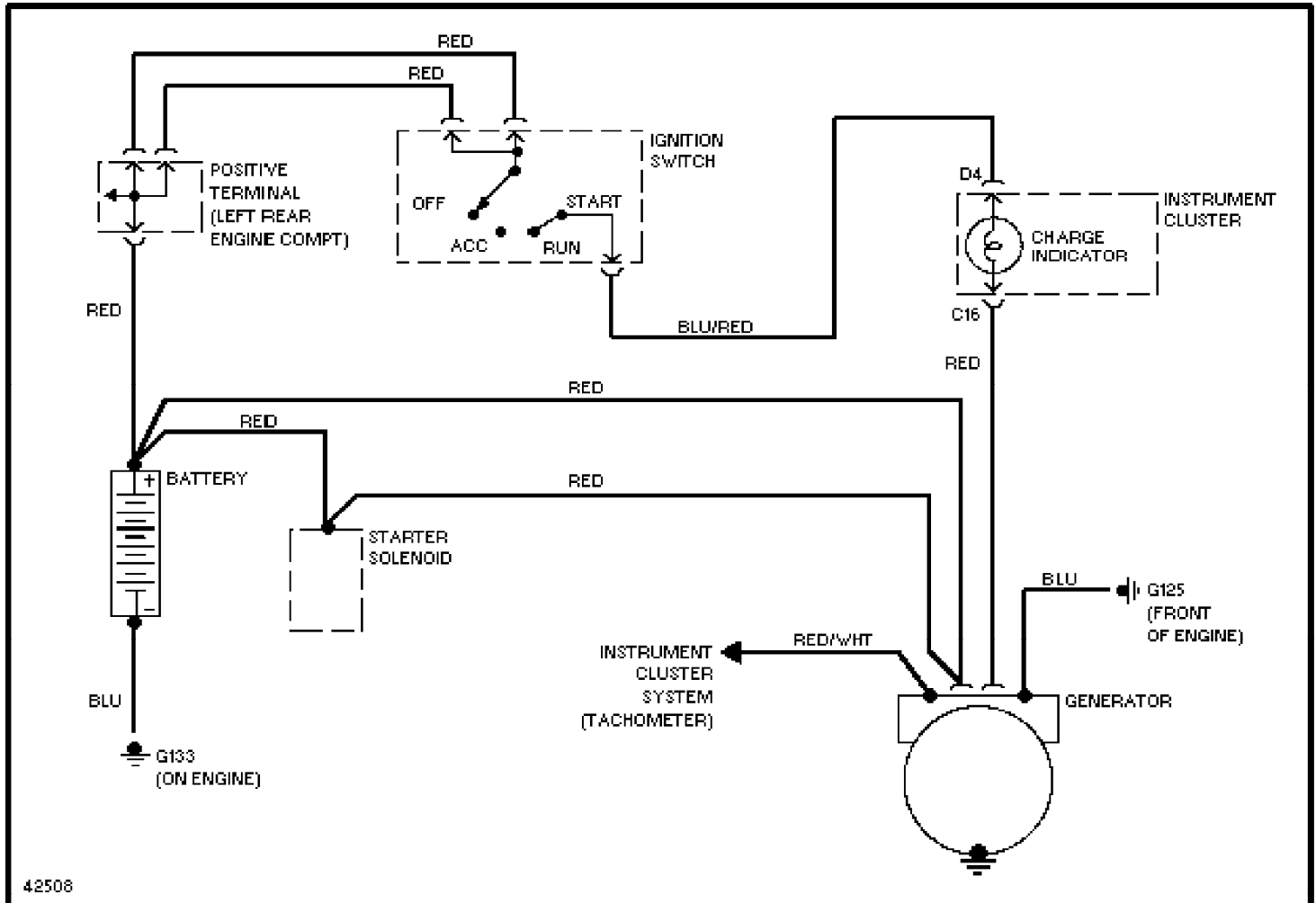

SYSTEM WIRING DIAGRAMS

Starting Circuit

1993 Volvo 940

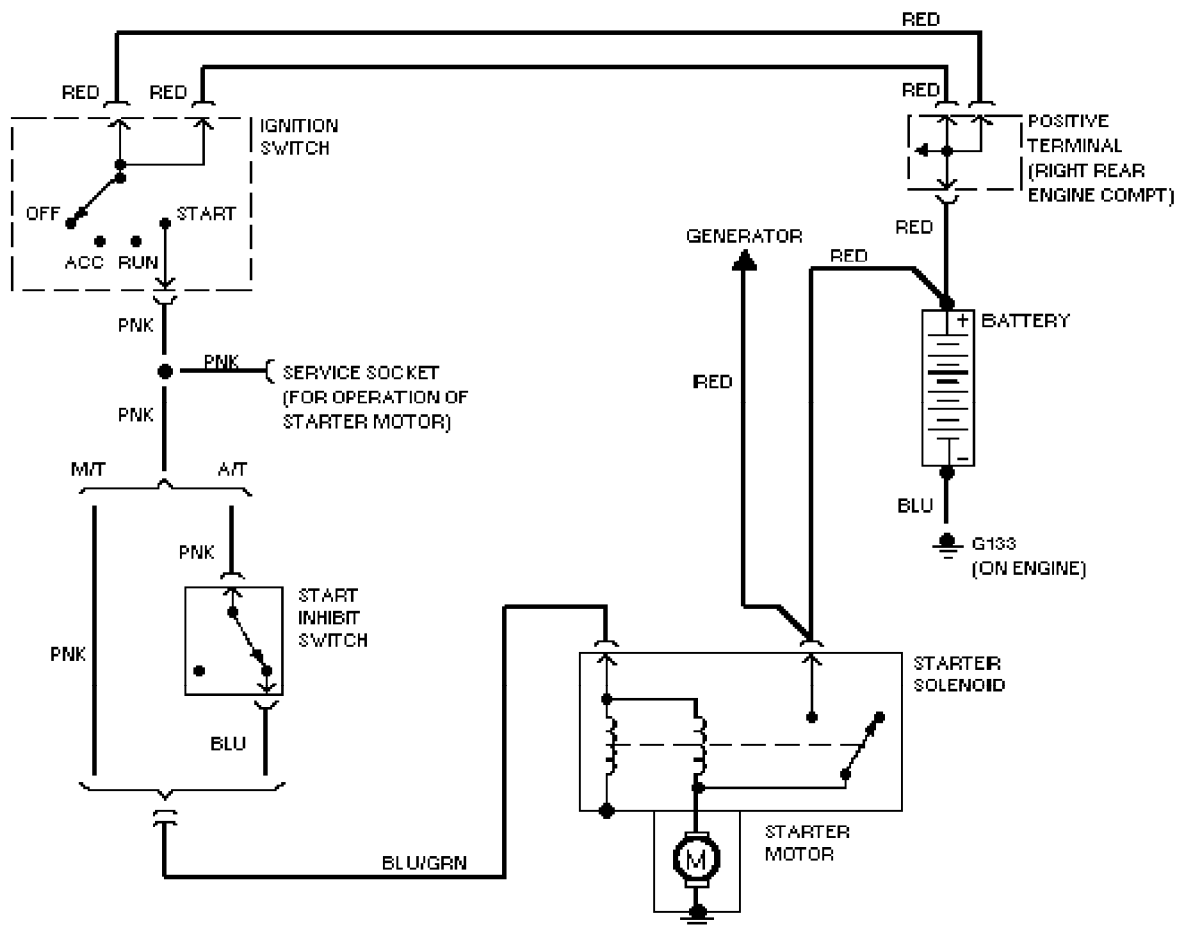

SYSTEM WIRING DIAGRAMS

Overdrive Circuit, A/T

1993 Volvo 940

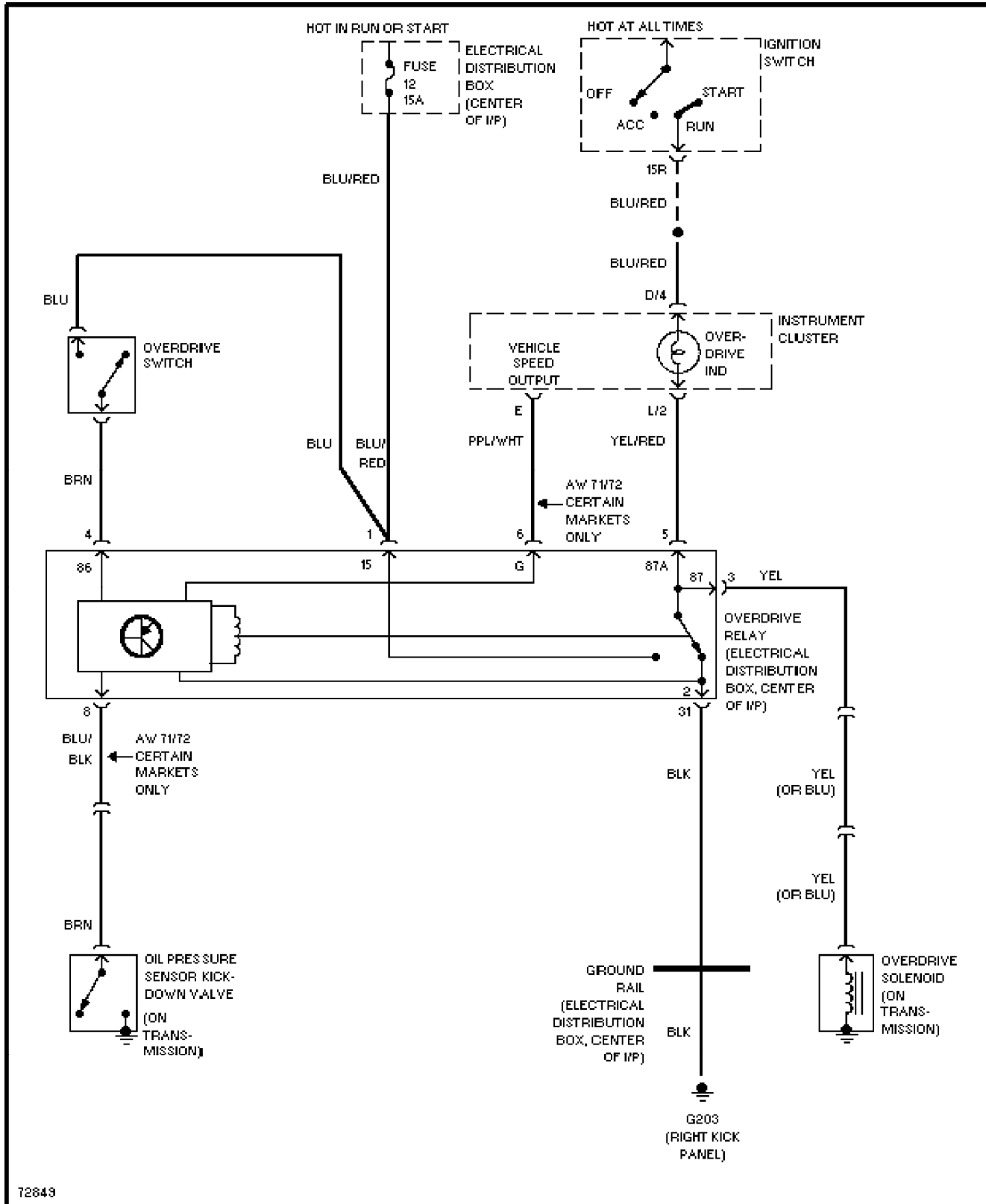

SYSTEM WIRING DIAGRAMS

Overdrive Circuit, M/T

1993 Volvo 940

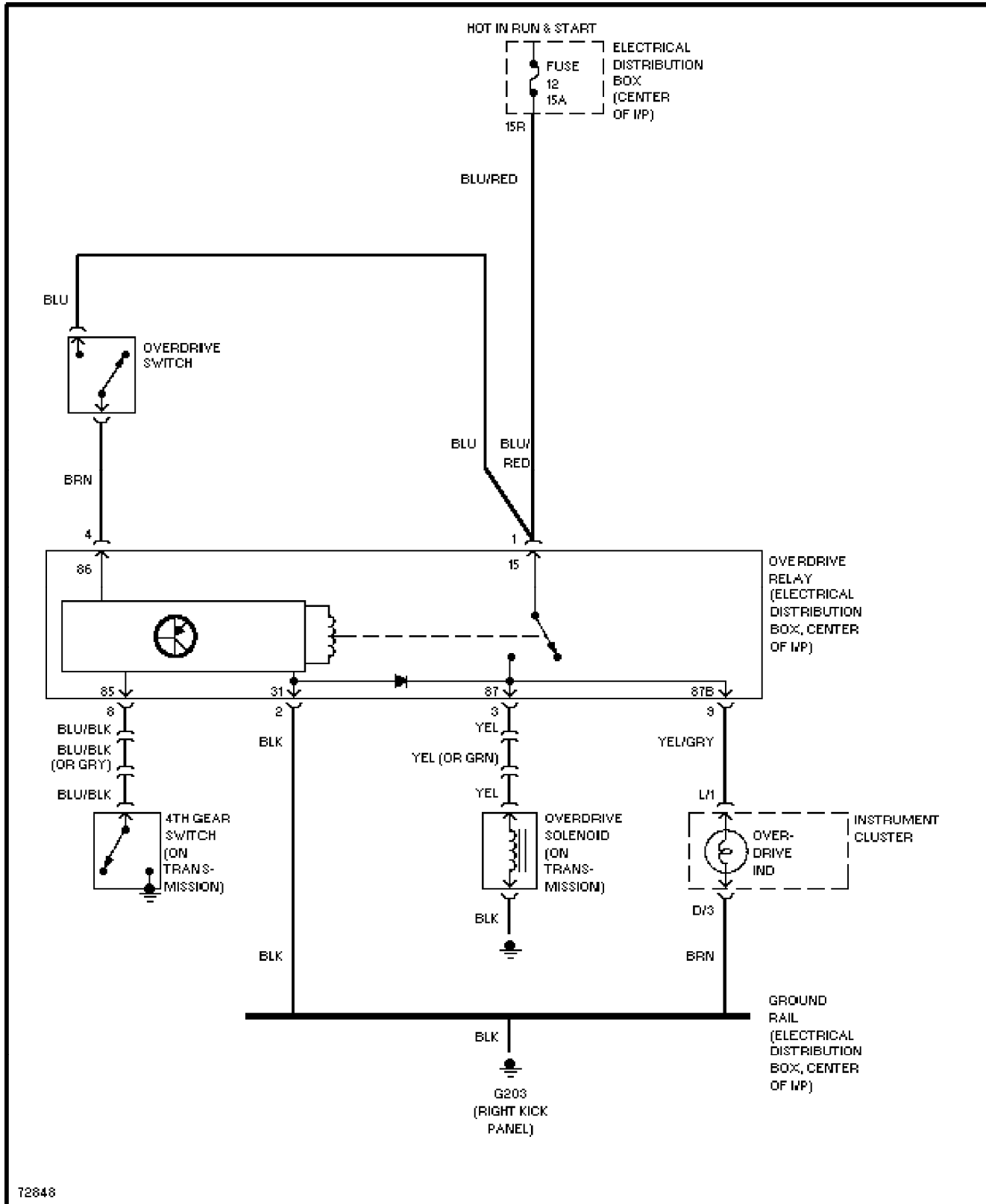

WIRING DIAGRAMS

Fig. 11: Memory Control Unit, Pwr Seat Sw (w/ Memory) (Grid 40-43)
1993 Volvo 940

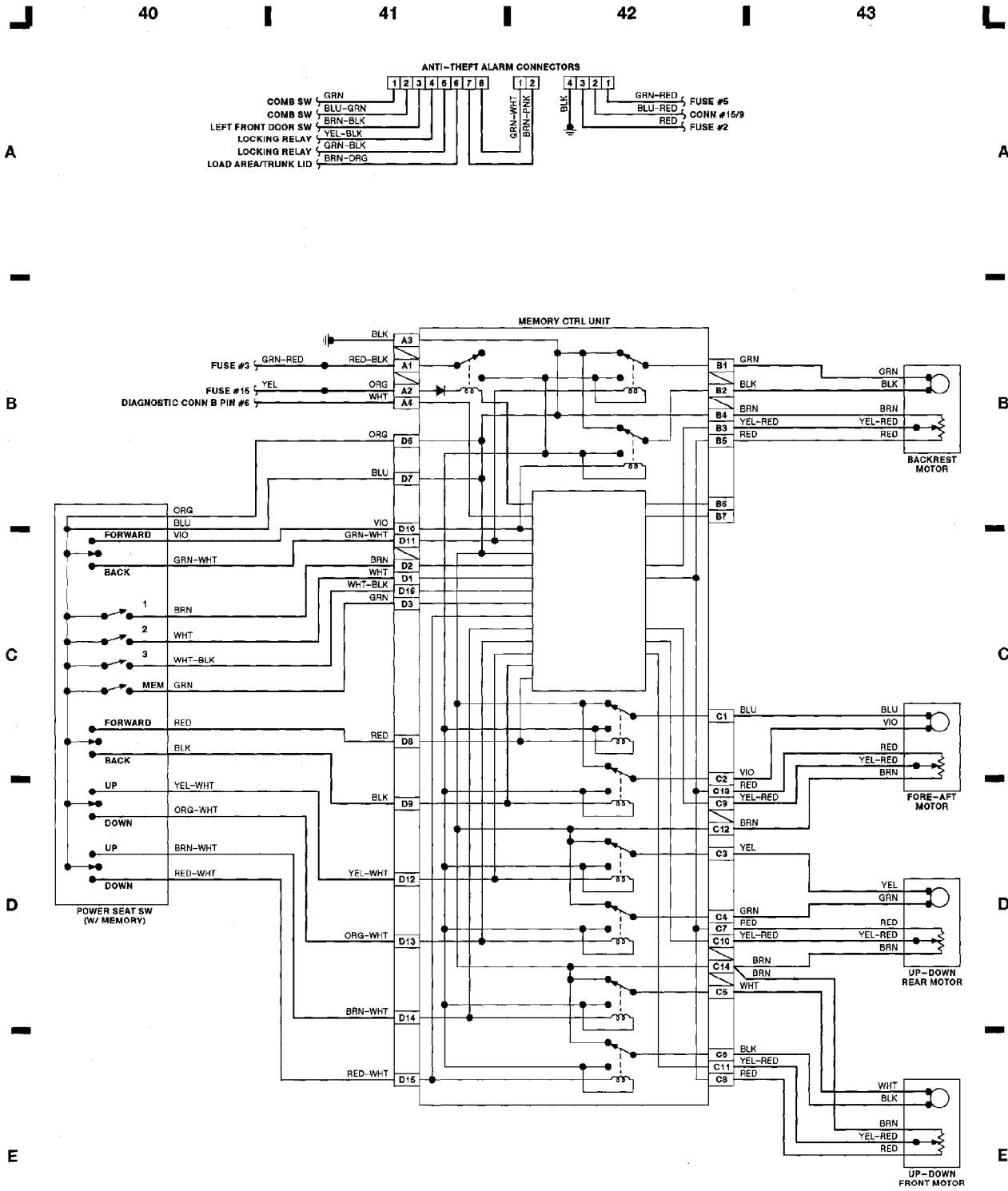

WIRING DIAGRAMS

Fig. 12: Defogger Sw, Pwr Mirror/Sunroof Sw, Taillight (Grid 44-47)

1993 Volvo 940

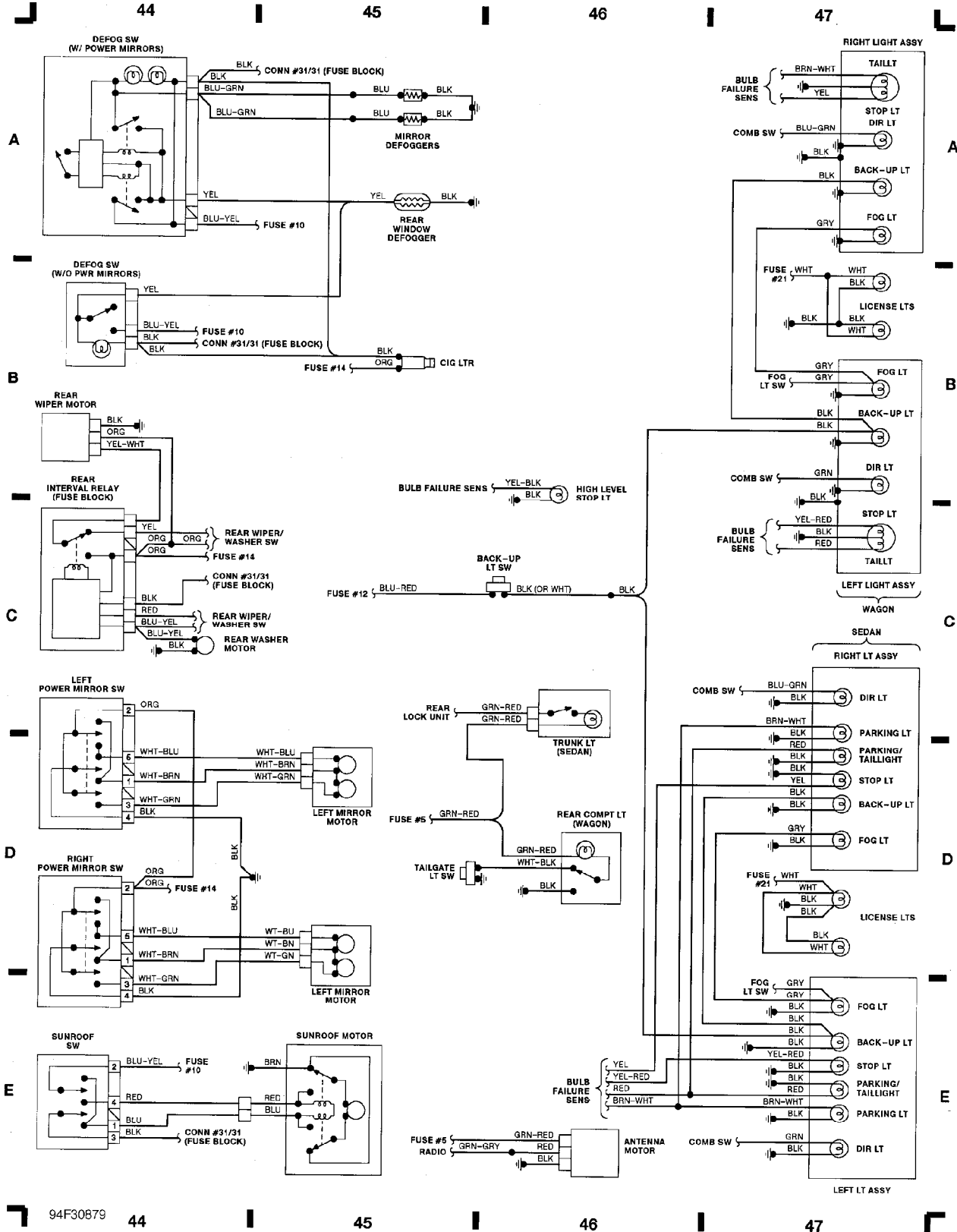

WIRING DIAGRAMS

Fig. 1: Engine Compartment, Headlights (Grid 1-3)

1993 Volvo 940

COMPONENT LOCATOR:

| | |
|---|-------------------|
| A/C COMPRESSOR | E 21 |
| ALTERNATOR | C 3 |
| AMBIENT TEMP GAUGE/SENSOR | A 19 |
| ANTENNA MOTOR | E 46 |
| ANTI-LOCK BRAKE SYSTEM (ABS) | A-B 29-31 |
| ANTI-THEFT ALARM CONNECTORS | A 41-42 |
| BACK-UP LT SW | C 45-46 |
| BATTERY | A 2 |
| BRAKE FLUID LEVEL SENSOR | B 35 |
| BULB FAILURE SENSOR | E 24 |
| CLG LIT | B 45 |
| COMB SW | A-B 24 |
| CONN #15/2 | B 18-19 |
| CONN #15/9 | B 16-17 |
| CONN #15/21 | B 17-18 |
| COOLANT FAN RELAY | A 18 |
| COOLANT TEMP SENSOR | A 35 |
| COURTESY LTS | C 24 |
| COURSE CTRL SYSTEM | C-D 28-30 |
| DEFOG SYSTEMS | A-B 44-45 |
| DIAGNOSTIC CONN A (LH 2.4 TURBO) | D 11 |
| DIAGNOSTIC CONN B (REGINA) | D 13 |
| DIAGNOSTIC CONN C | D 5 |
| DIAGNOSTIC CONN D | D 13 |
| DOOR LTS | E 29-30 |
| DOOR SWS | C-D 25-26 |
| ECC CTRL UNIT | C-E 23 |
| ECC POWER UNIT | E 20 |
| EZK IGNITION SYSTEM | D-E 9 |
| ECU (LH 2.4 TURBO) | D-E 9 |
| EZK IGNITION SYSTEM | C-D 7 |
| ECU (LH 2.4) | C-D 7 |
| FLASHER RELAY | A 27 |
| FOG LT SW/RELAY | D-E 28 |
| FUEL INJECTOR ECM (LH 2.4 TURBO) | A-B 8 |
| FUEL INJECTOR ECU (LH 2.4) | A-C 4 |
| FUEL INJECTOR ECU (REGINA) | A-C 12 |
| FUEL PUMP (REGINA) | D 12 |
| FUEL PUMPS (LH 2.4 TURBO) | B-C 11 |
| FUEL PUMPS (LH 2.4) | D 4 |
| FUEL SENSOR | B 35 |
| FUEL SYSTEM RELAY (LH 2.4 TURBO) | B 11 |
| FUEL SYSTEM RELAY (LH 2.4) | C 4 |
| FUEL SYSTEM RELAY (REGINA) | C 12 |
| FUS LINK | A 3 |
| FUSE & RELAY BLOCK (PARTIAL) | B-D 16-19 |
| FUSE & RELAY BLOCK (PARTIAL) | A-B 22-23 |
| FUSE AMP CHART | E 19 |
| GLOVE BOX LTS/SW | E 25 |
| HEATER CTRL SW | C 20 |
| HI PRES SENSOR | C 20 |
| HORN SWS | C 2 |
| IGNITION COIL (LH 2.4) | E 6 |
| IGNITION SW | E 16 |
| IGNITION SYSTEM ECU (REGINA) | C-D 15 |
| INHIBITOR SW | B-C 12 |
| INSTRUMENT CLUSTER | A-E 32-33 |
| INSTRUMENT PANEL SW | D-E 34-35 |
| ILLUMINATION LTS | D-E 34-35 |
| INTERVAL RELAY (FRONT WIPERS) | C 44 |
| INTERVAL RELAY (REAR WIPERS) | C 44 |
| JUNCTION BLOCK | A-B 2-3 |
| LIGHT RELAY | A-B 27 |
| LIGHT SW | A-B 27 |
| LO PRES SENSOR | A 17 |
| MCC CTRL UNIT | B-C 23 |
| MEMORY CONTROL UNIT | B-E 40-43 |
| O2 SENSOR (LH 2.4) | C 7 |
| O2 SENSOR (REGINA) | C 15 |
| OIL PRES SENSOR | C 35 |
| OVERDRIVE SYSTEM | A-B 20-21 |
| PARK BRAKE SW | B 55 |
| POWER DOOR LOCKS | D-E 38-39 |
| POWER MIRRORS | C-D 44-45 |
| POWER SEAT SW | B-D 39 |
| POWER STAGE (LH 2.4 TURBO) | E 11 |
| POWER WINDOW/HEATED SEAT RELAY | B-C 20 |
| POWER WINDOWS | D-E 36-37 |
| RADIO INTERFERENCE SUPPRESSION RELAY (LH 2.4 TURBO) | C-D 11 |
| RADIO INTERFERENCE SUPPRESSION RELAY (LH 2.4) | B 7 |
| RADIO INTERFERENCE SUPPRESSION RELAY (REGINA) | B 15 |
| REAR SEAT BELT SW/LT | A 37-38 |
| REX POWER STAGE/IGNITION COIL (REGINA) | E 19 |
| RHEOSTAT & CLOCK ADJUSTER | C-D 35 |
| SEAT BELT REMINDER | A 36 |
| SEAT HEATER SWS | B-C 38, A-B 38-39 |
| SHIFT LOCK RELAY | E 31 |
| SHIFT LOCK SOL | E 31 |
| SPEED SENSOR | C 35 |
| SPEED WARN CHIME | D 34 |
| SRS SENSOR MODULE | C-D 31 |
| STARTER | B-C 3 |
| STOP LT SW | D 28 |
| SUNROOF SW | E 44-45 |
| THERMOSTAT | A 17 |
| TRANSIENT SURGE PROTECTOR | B 26 |
| TRUNK/REAR COMPARTMENT LTS | C-D 46 |
| VANITY MIRROR LTS | E 28 |
| WASHER FLUID LEVEL SENSOR | C 35 |
| WIPER/WASHER SW (FRONT) | D-E 3 |
| WIPER/WASHER SW (REAR) | D-E 27 |

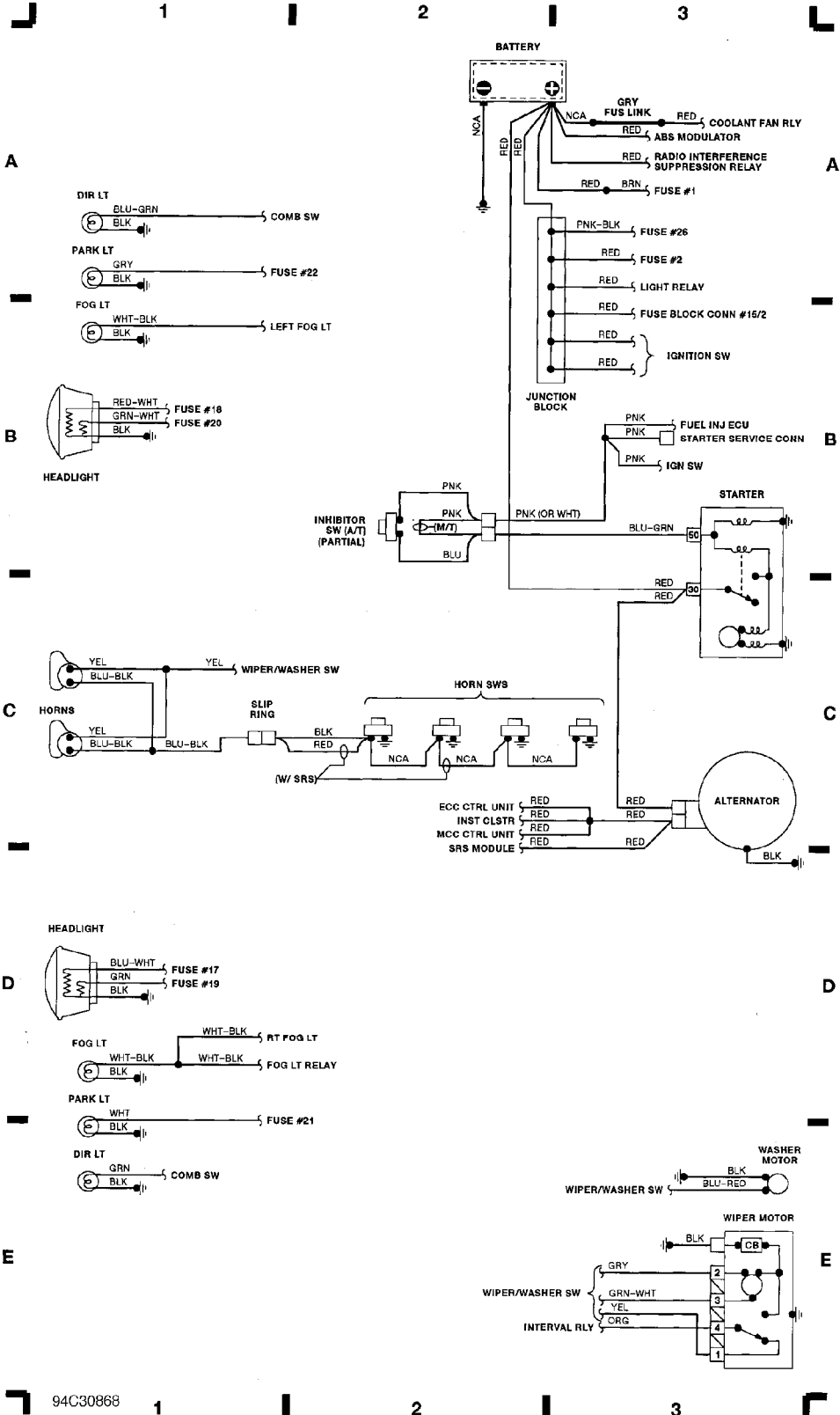

WIRING DIAGRAMS
Fig. 2: Fuel Inj Ecu (LH 2.4), Ignition Coil (Grid 4-7)
 1993 Volvo 940

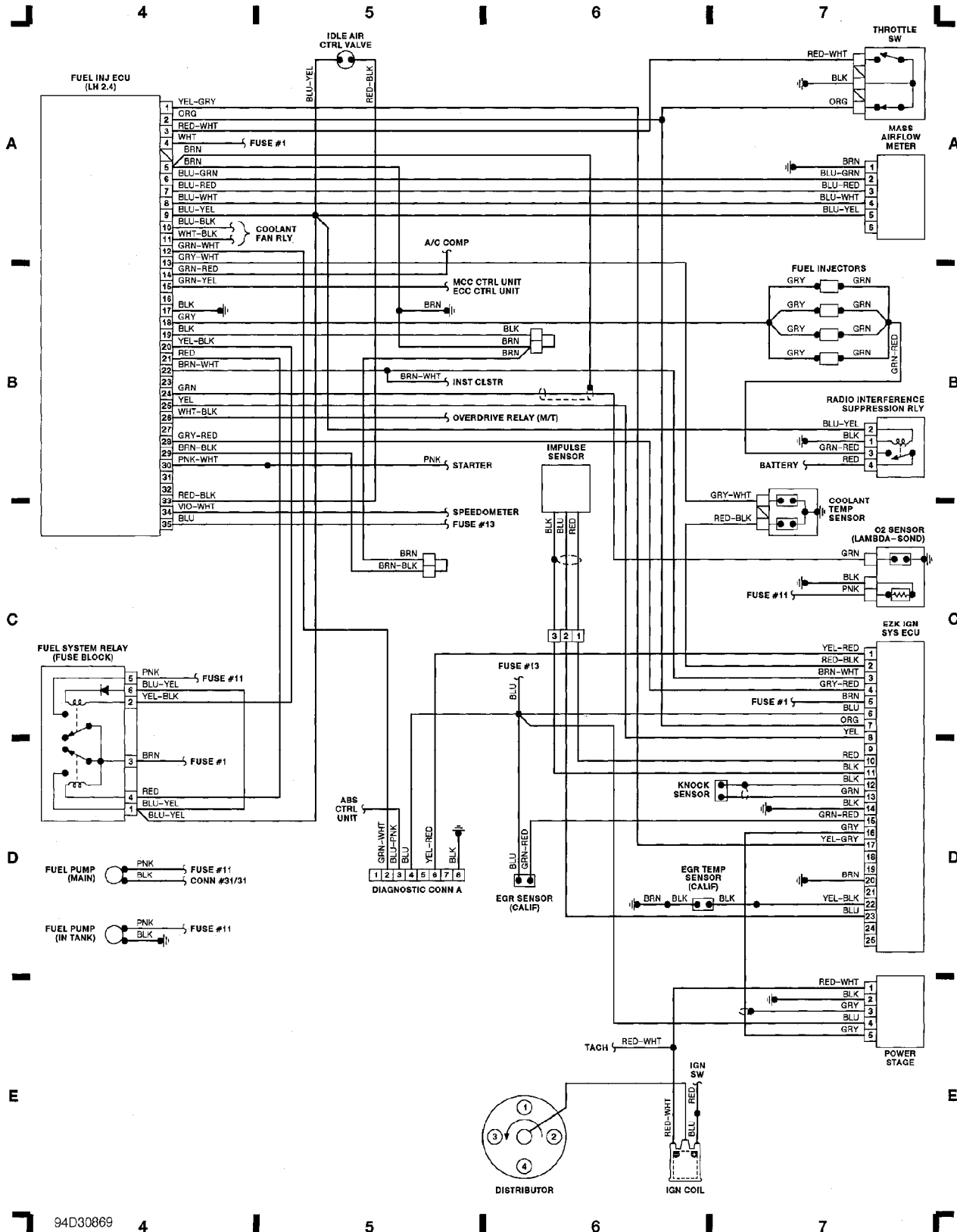

WIRING DIAGRAMS
Fig. 3: Fuel Inj Ecu (LH 2.4 Turbo) (Grid 8-11)
 1993 Volvo 940

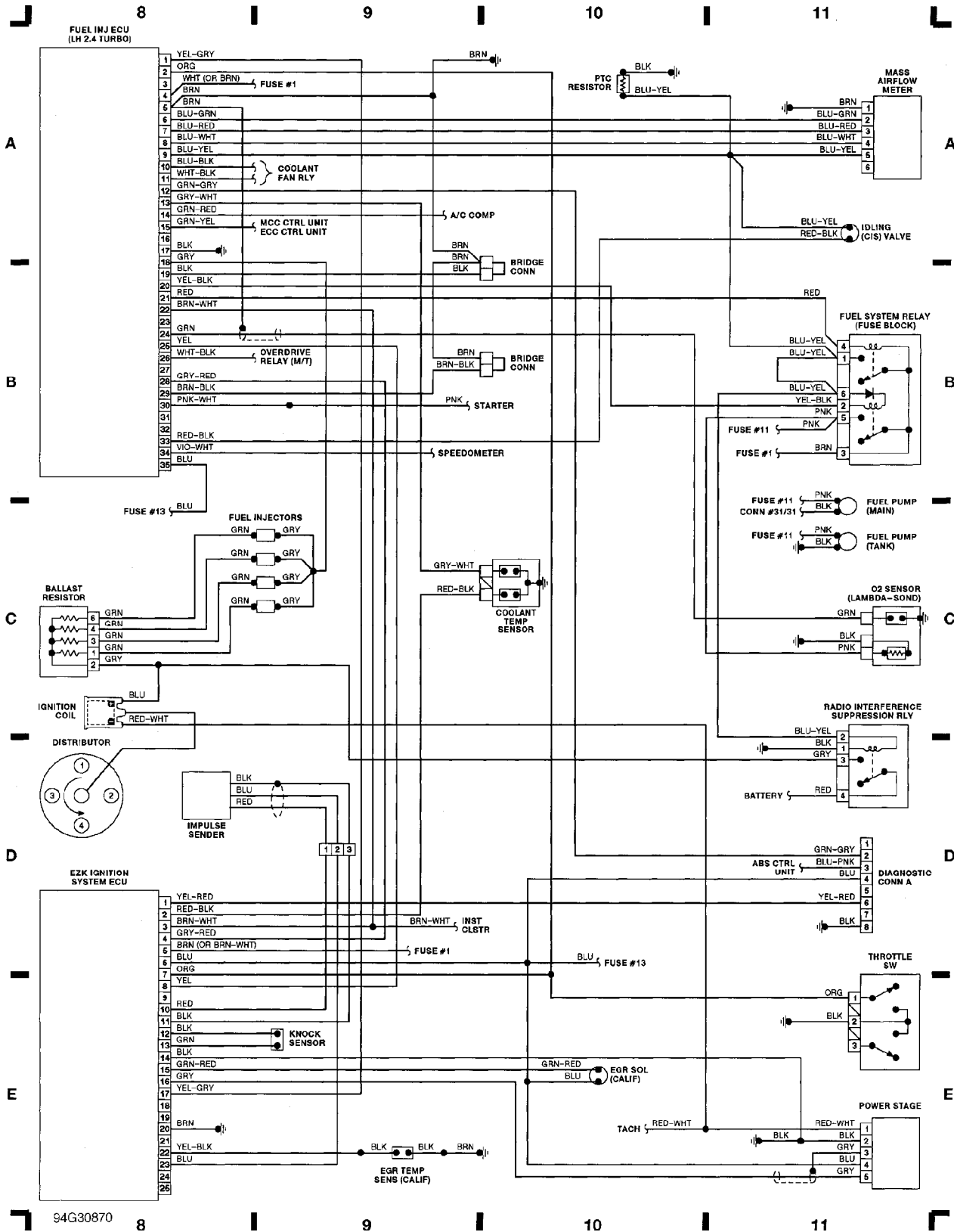

WIRING DIAGRAMS
Fig. 4: Fuel Inj Ecu (Regina), Ign Sys ECU (Grid 12-15)
 1993 Volvo 940

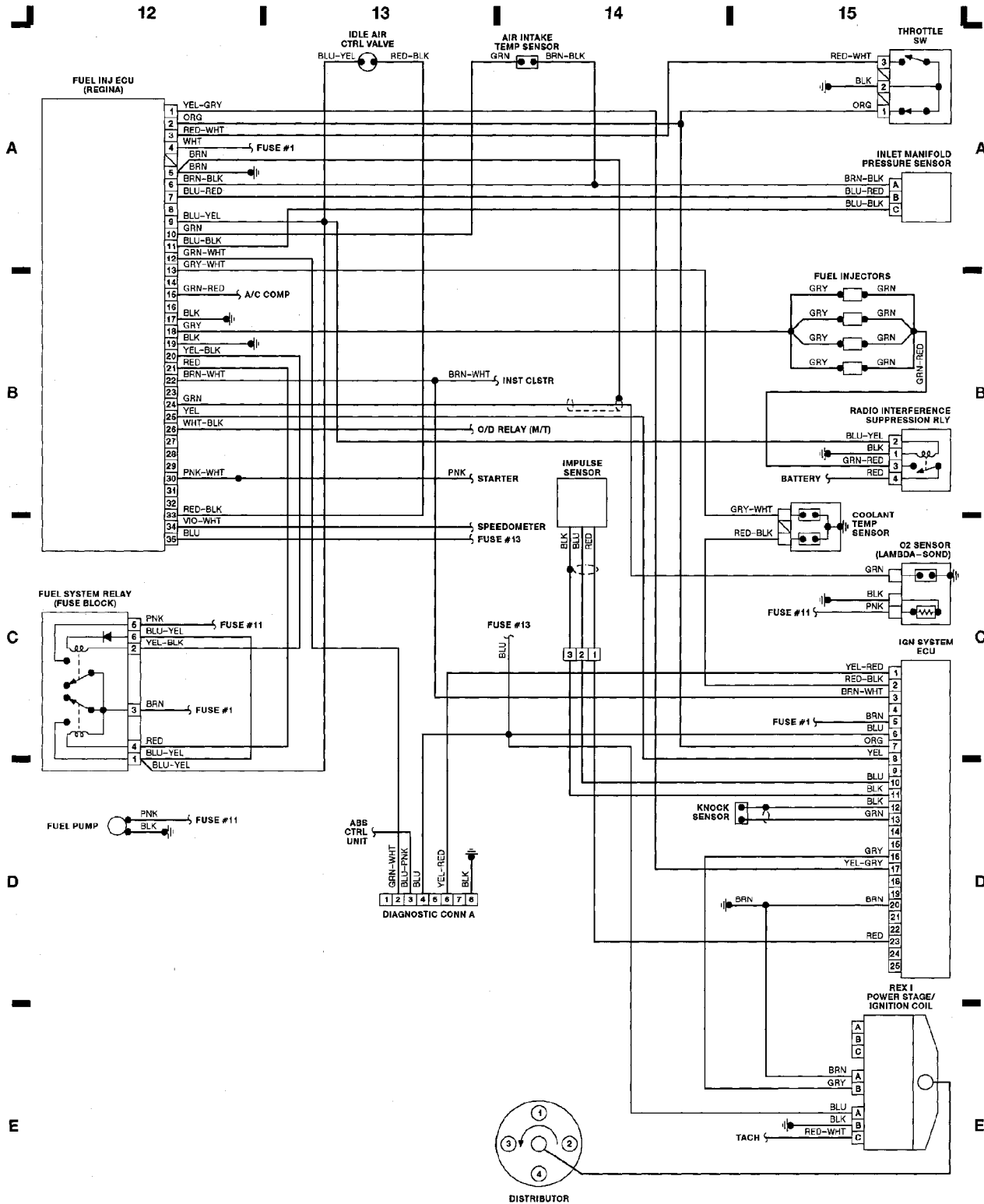

WIRING DIAGRAMS

Fig. 5: Fuse & Relay Block (Partial), Ignition Sw (Grid 16-19) 1993 Volvo 940

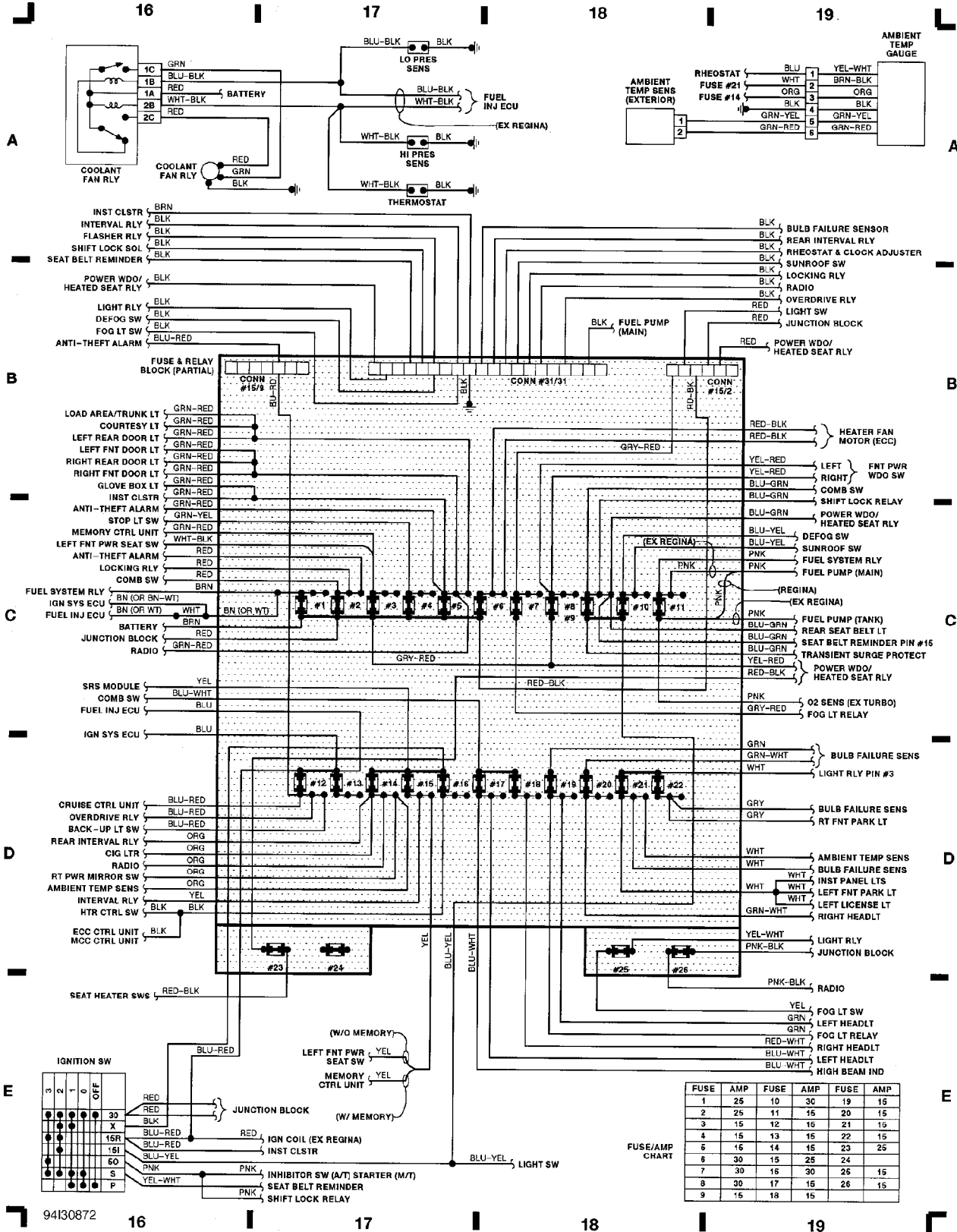

WIRING DIAGRAMS
Fig. 6: ECC Control Unit, MCC Control Unit (Grid 20-23)
 1993 Volvo 940

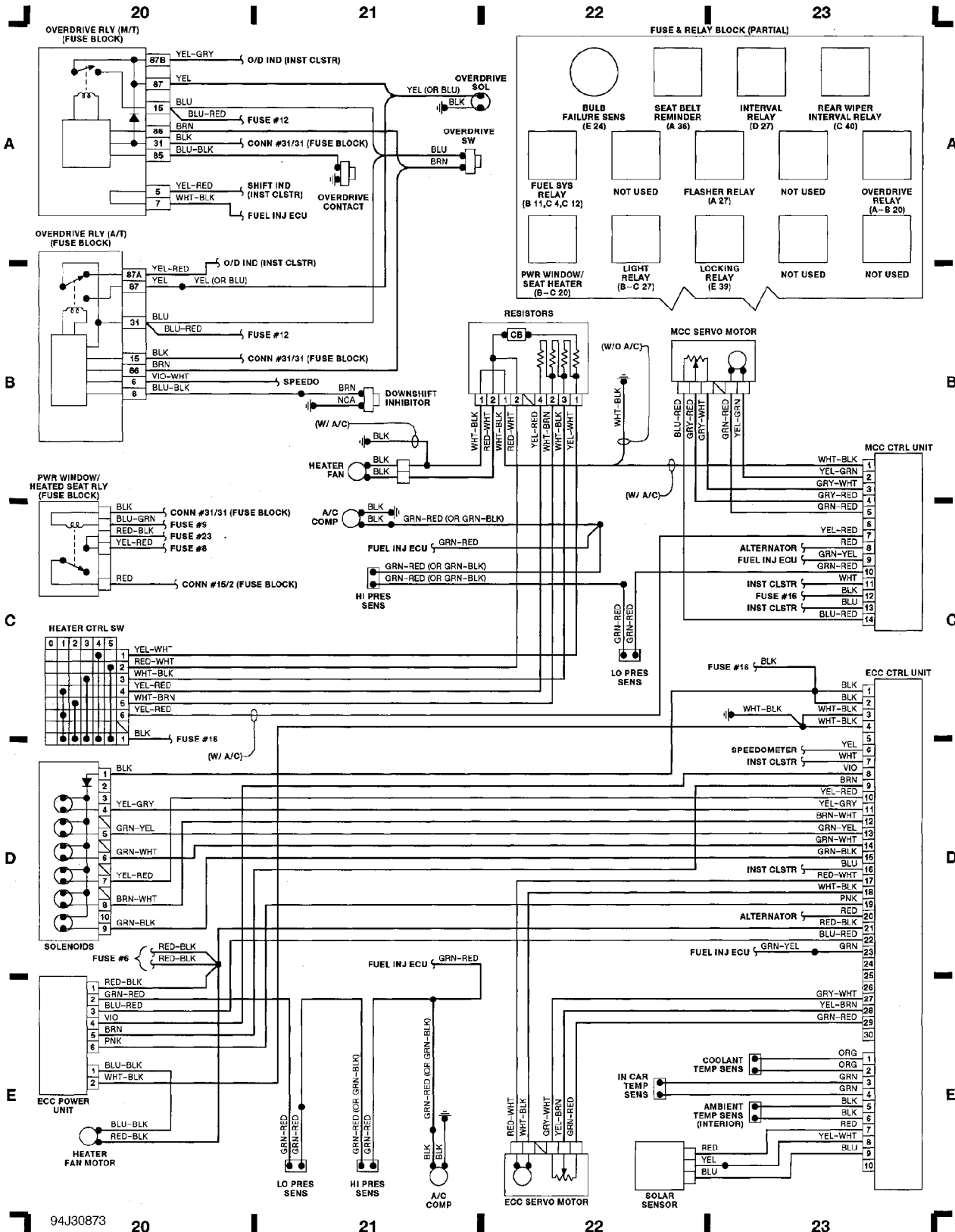

WIRING DIAGRAMS

Fig. 7: Combo Switch, Courtesy Lights, Light Relay (Grid 24-27)
1993 Volvo 940

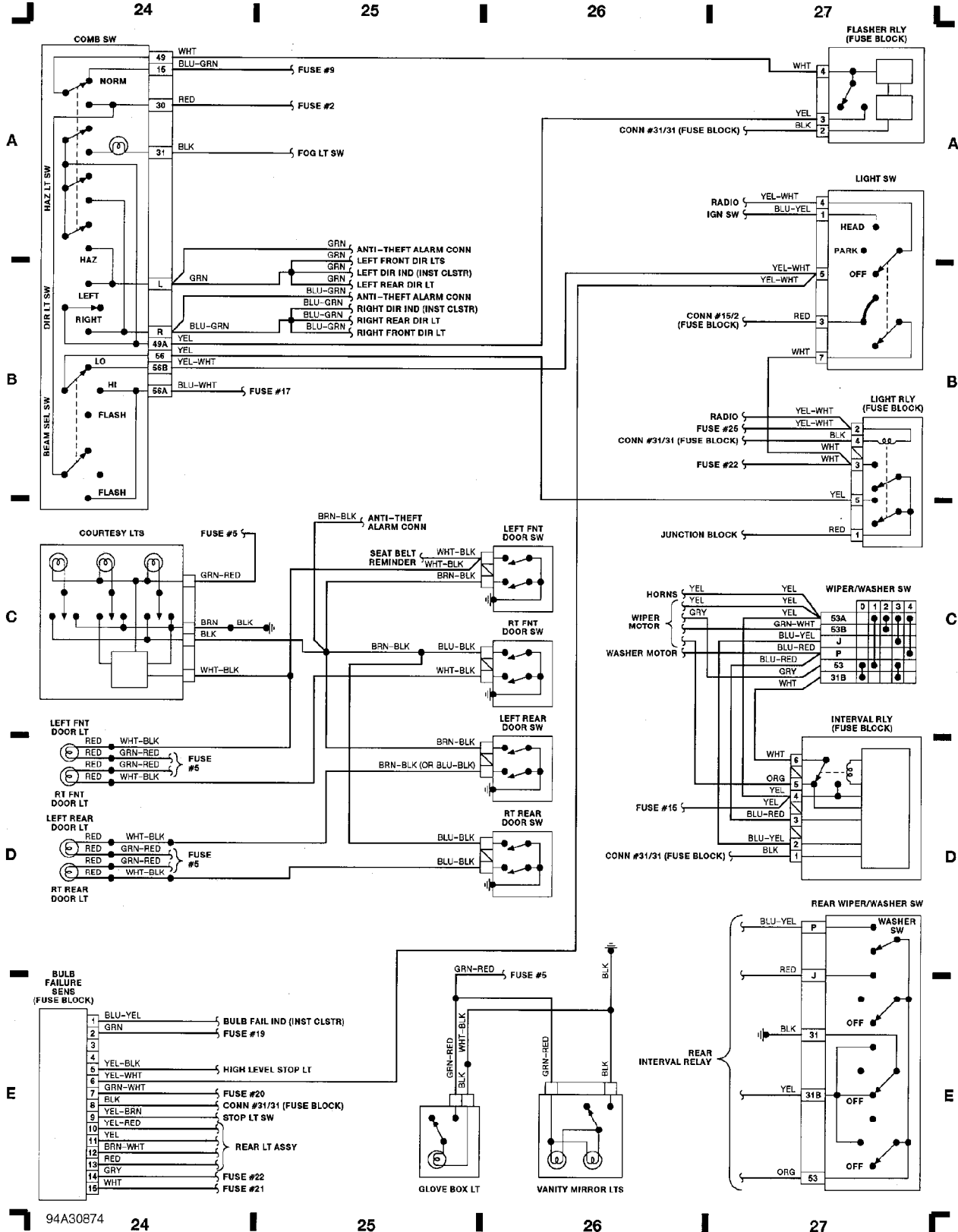

WIRING DIAGRAMS

Fig. 8: ABS Control Unit, SRS System, Fog Light Sw (Grid 28-31)
1993 Volvo 940

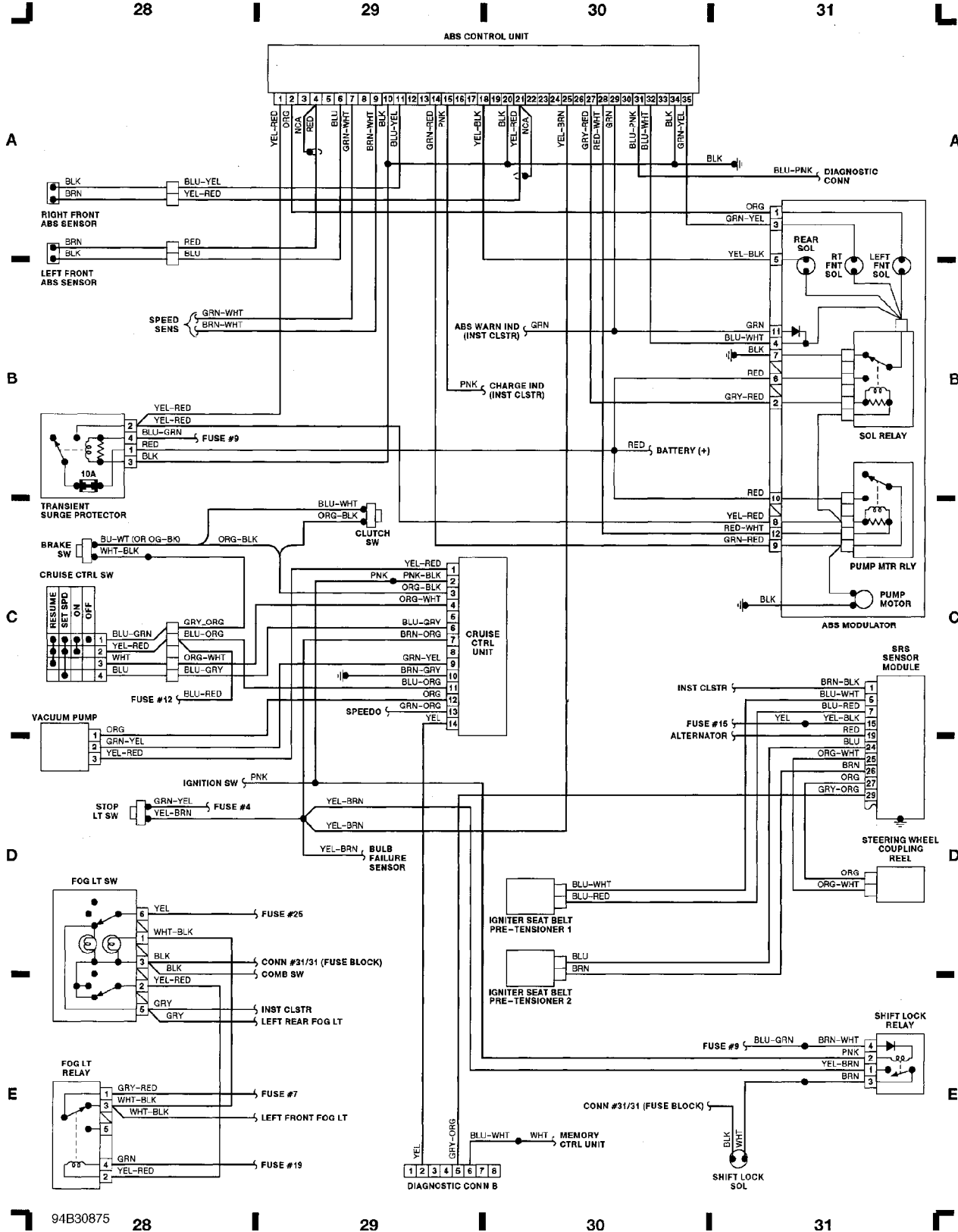

WIRING DIAGRAMS
Fig. 9: Instrument Cluster (Grid 32-35)
 1993 Volvo 940

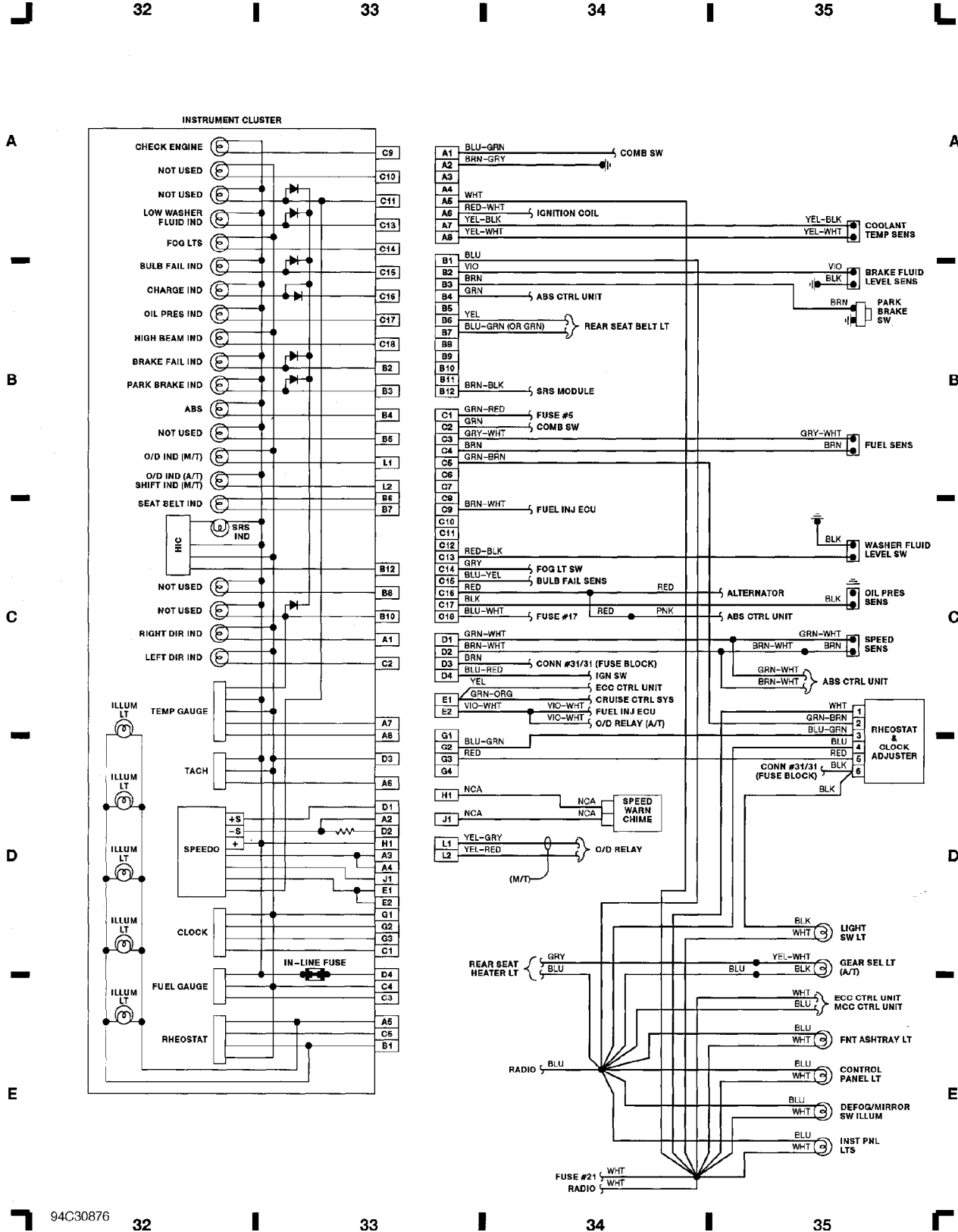

WIRING DIAGRAMS

Fig. 10: Left Fnt Pwr Seat Sw (W/O Memory) (Grid 36-39)

1993 Volvo 940

